

Step 1. Install Base Plates and Slides

- Install hinge bases as shown in Figure 3, using #8-32 x 5/16" flat-head self-tapping screws provided for standard applications.
- Locate slide in upper inside corner of case as shown in Figure 2. Set back the slide from the front edge of the case by the amount shown in Figure 2. Repeat with lower slide.

figure 2

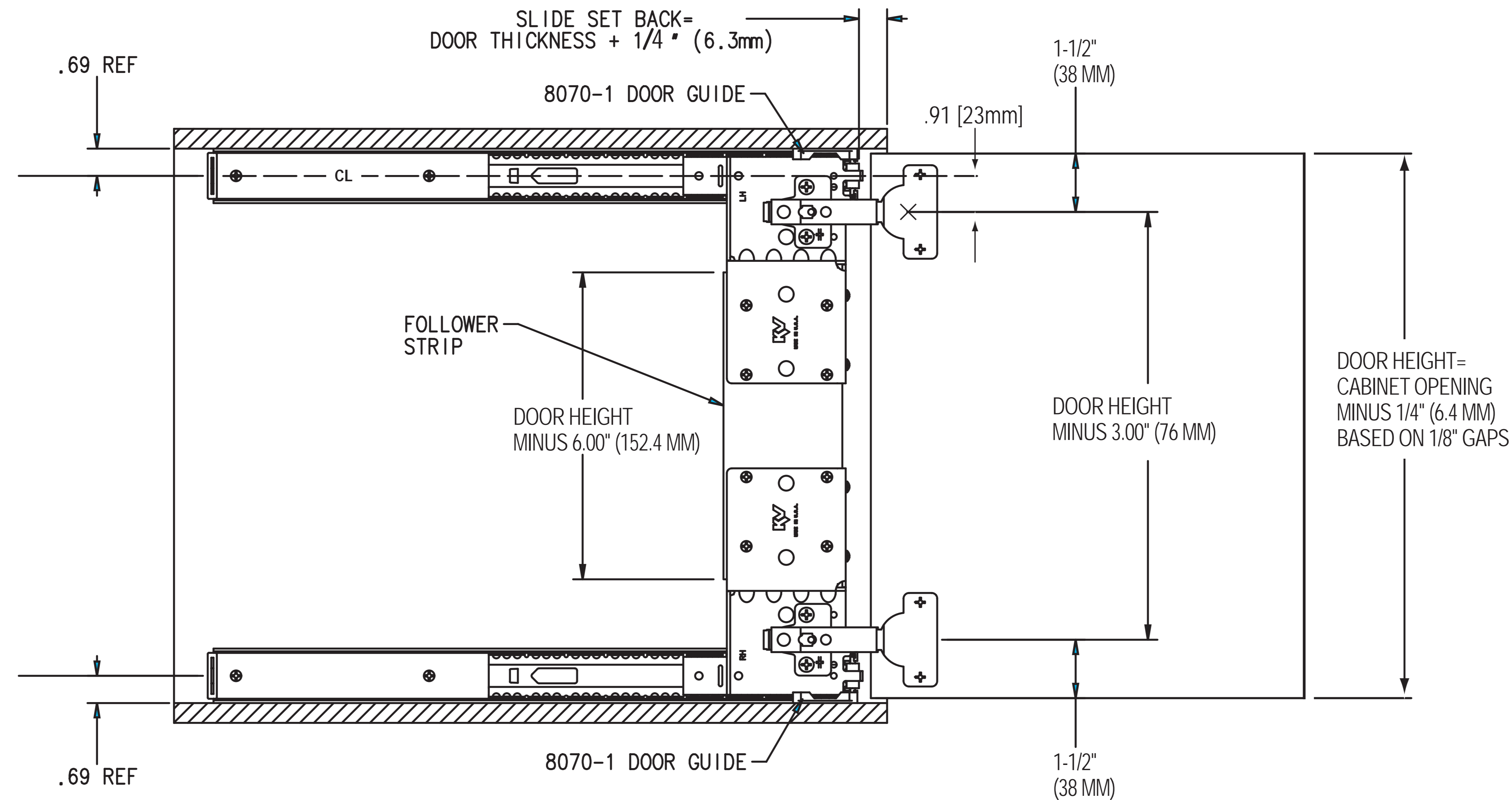

Step 2. Follower Strip, Hinge Cup, & Hinge Installation

- Cut a follower strip 6" shorter than vertical door height. The follower strip should be cut from 3/4" thick x 3" wide stock. Fasten follower strip to slide bracket with (6) #6 x 13/32" pan-head self-tapping screws.
- For standard corner mounted slide installations, locate the horizontal centerline of the cup holes 1-1/2" from the top and bottom edge of the door. Use the appropriate TAB/DBE dimension and drill size per application chart shown in Chart 2. Bore cup holes. Always bore a test block first to verify hinge cup locations.
- Install hinge cups with #6x7/16" flat-head self-tapping screws provided.

Step 3. Door and Guide Block Installation

- Install Doors. Slowly retract, open and close each door, checking for proper operation and door alignment.
- Refer to Figure 8 for horizontal, vertical, and depth adjustments for hinge.
- Refer to Figure 6 for door glide location.
- Install two guide blocks per door using (2) #6 X 13/32" pan-head self-tapping screws per block.

figure 3

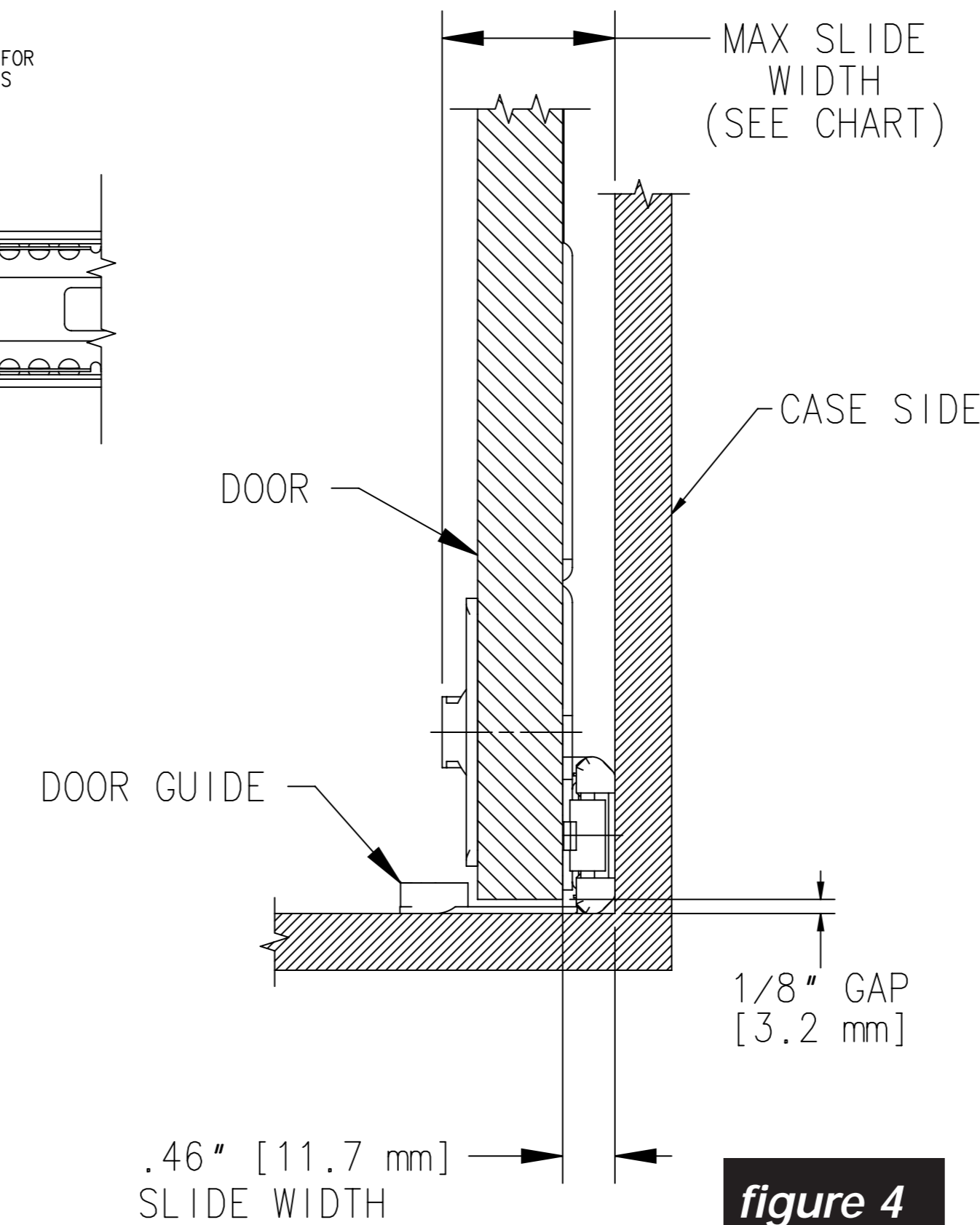
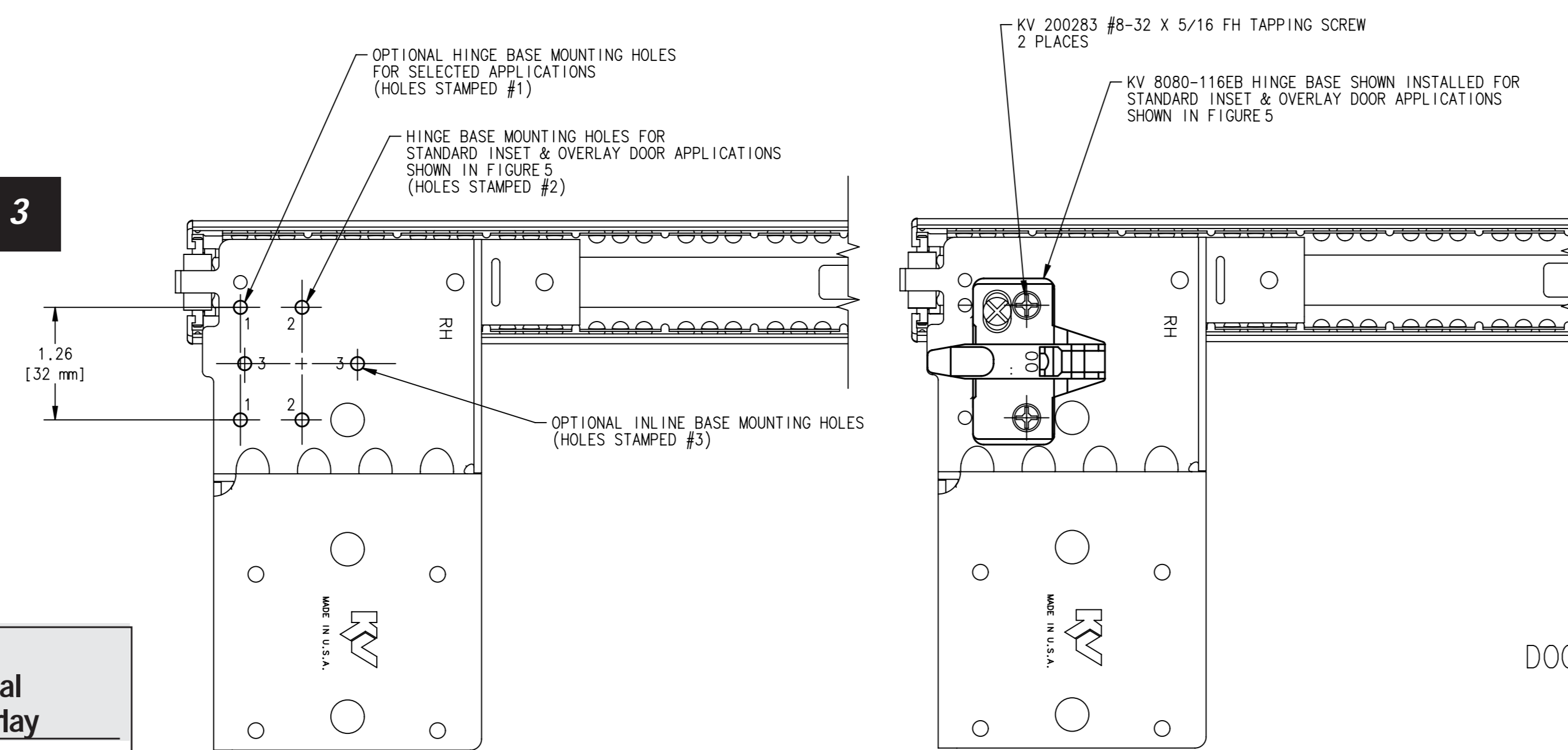

figure 4

chart 2

Hinge Options	Hinge Description	Door Thickness	Edge Bore Distance (DBE)	Hinge Cup Bore Dia.	Maximum Slide Width Including Hinge For Partition Installations	Partial Overlay
8080	Standard Hinge	3/4" (19mm)	1/4" (6mm)	1-3/8" (35mm)	1-23/32" (43.7mm)	N/A
8080FS	Standard Hinge w/Free Swing Knuckle	3/4" (19mm)	1/4" (6mm)	1-3/8" (35mm)	1-23/32" (43.7mm)	N/A
8080L	Overlay Door	3/4" (19mm)	7/16" (11mm)	1-37/64" (40mm)	1-23/32" (43.7mm)	13/32" (10.3mm)
8085	Thick Door	1" (25.4mm)	5/16" (8mm)	1-37/64" (40mm)	2-3/32" (53.2mm)	N/A
8086	Extra Thick Door	1-1/4" (32mm)	1/2" (12.7mm)	1-37/64" (40mm)	2-13/32" (61mm)	N/A

FRAMELESS APPLICATIONS

Standard or Free Swing Inset

Frameless, inset applications with 3/4" thick door

- 8080 HKEZSEB (Black)
- 8080 HKEZFEB (Black)

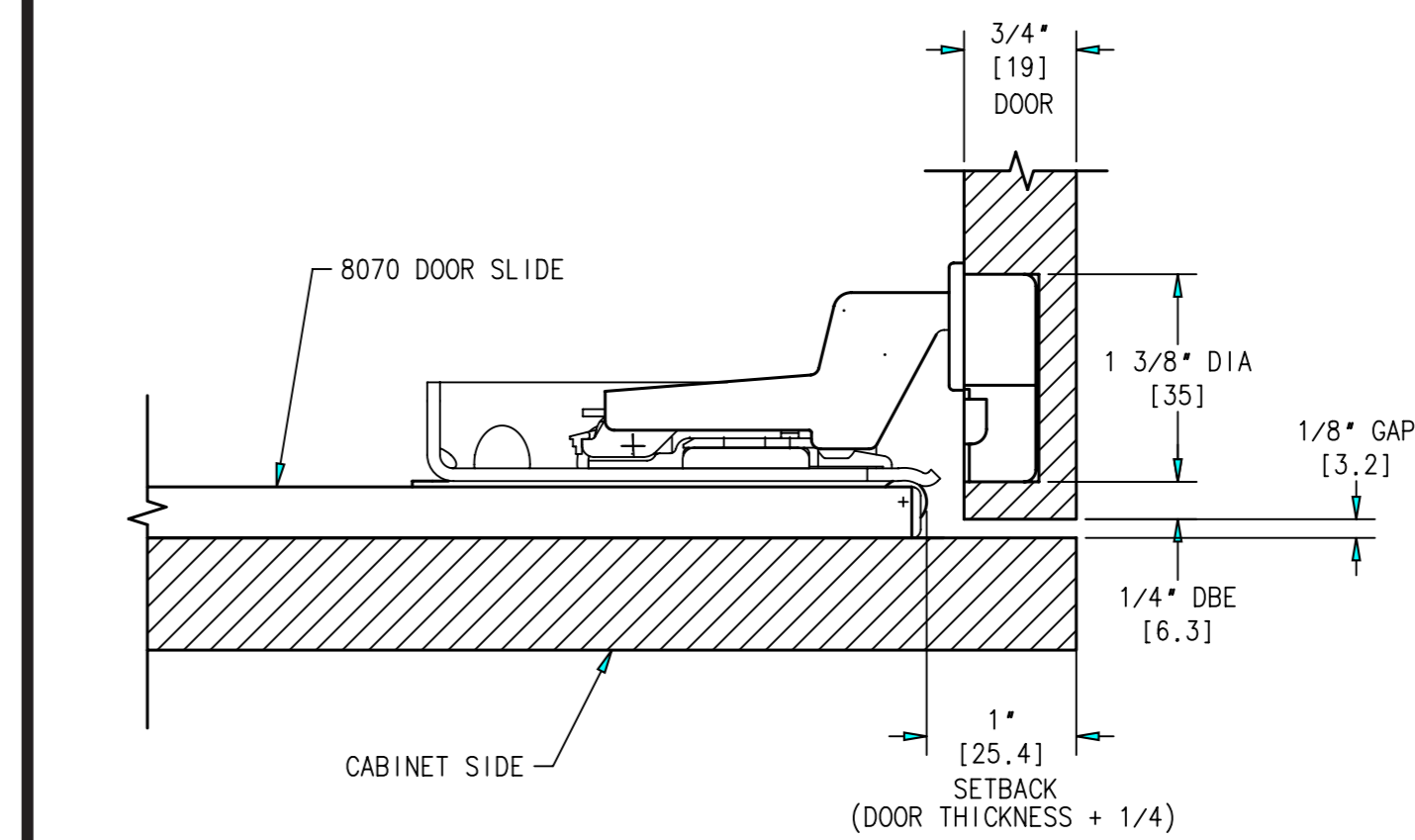

Partial Overlay

Frameless applications with 3/4" thick door. Maximum overlay with full hinge adjustment is 13/32"

- 8080 HEZLEB (Black)

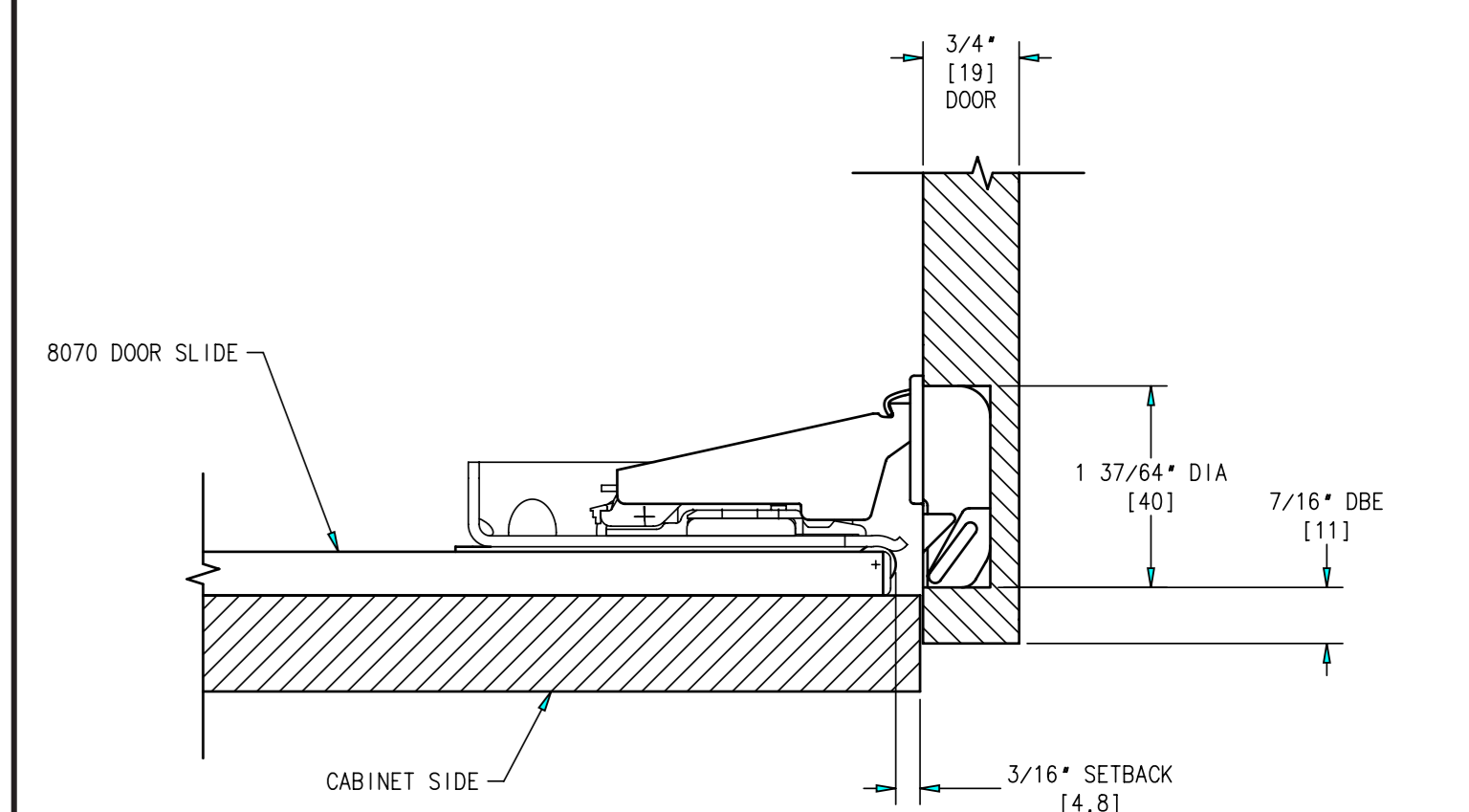

Thick Inset

Frameless inset applications with 1" thick door. Rear corner of door may be beveled at 45 degrees to use doors up to 1-1/4" thick.

- 8085 HKEZTEB (Black)

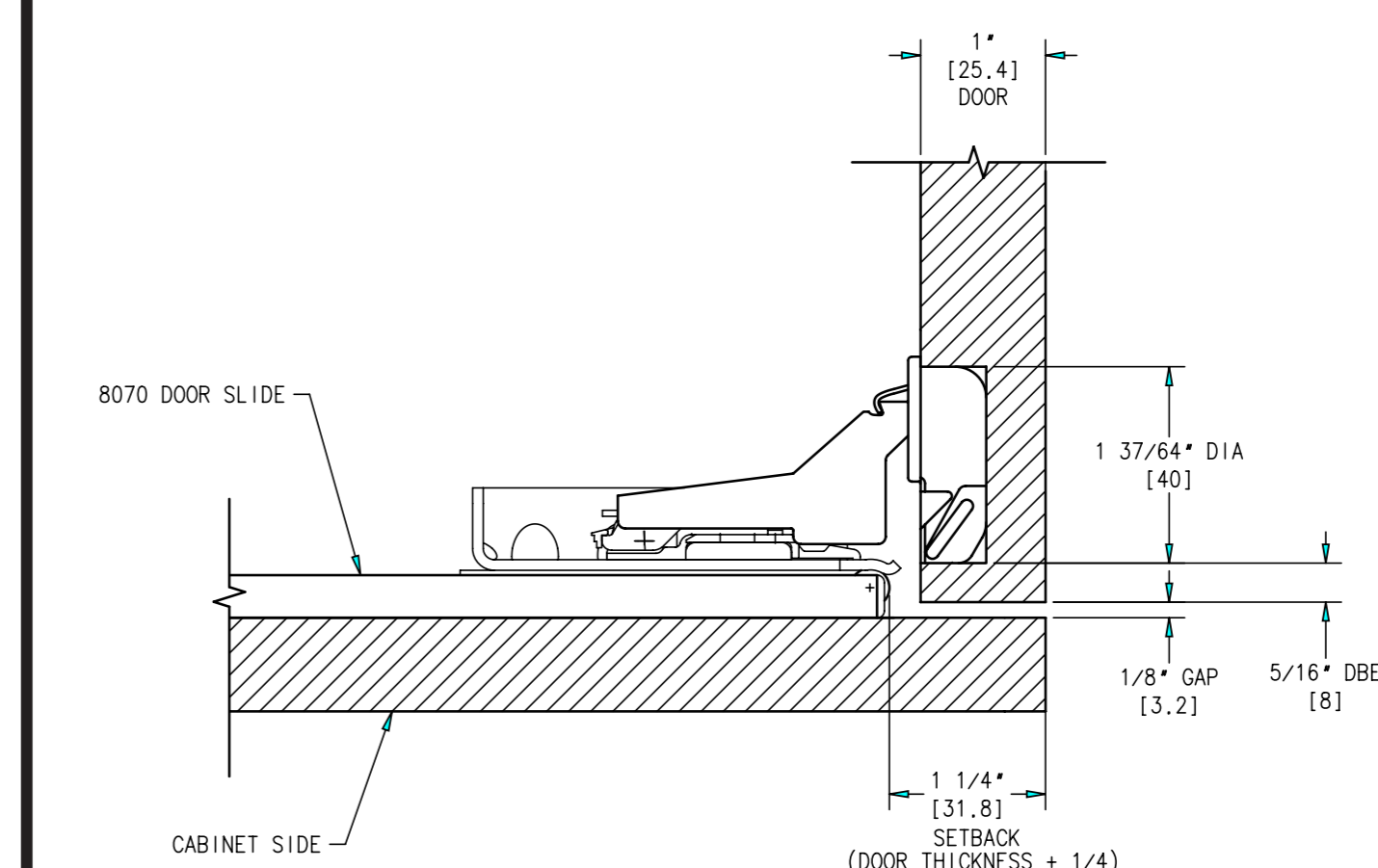

Extra Thick Inset

Frameless inset applications with 1-1/4" thick door.

- 8086 HKEZXEB (Black)

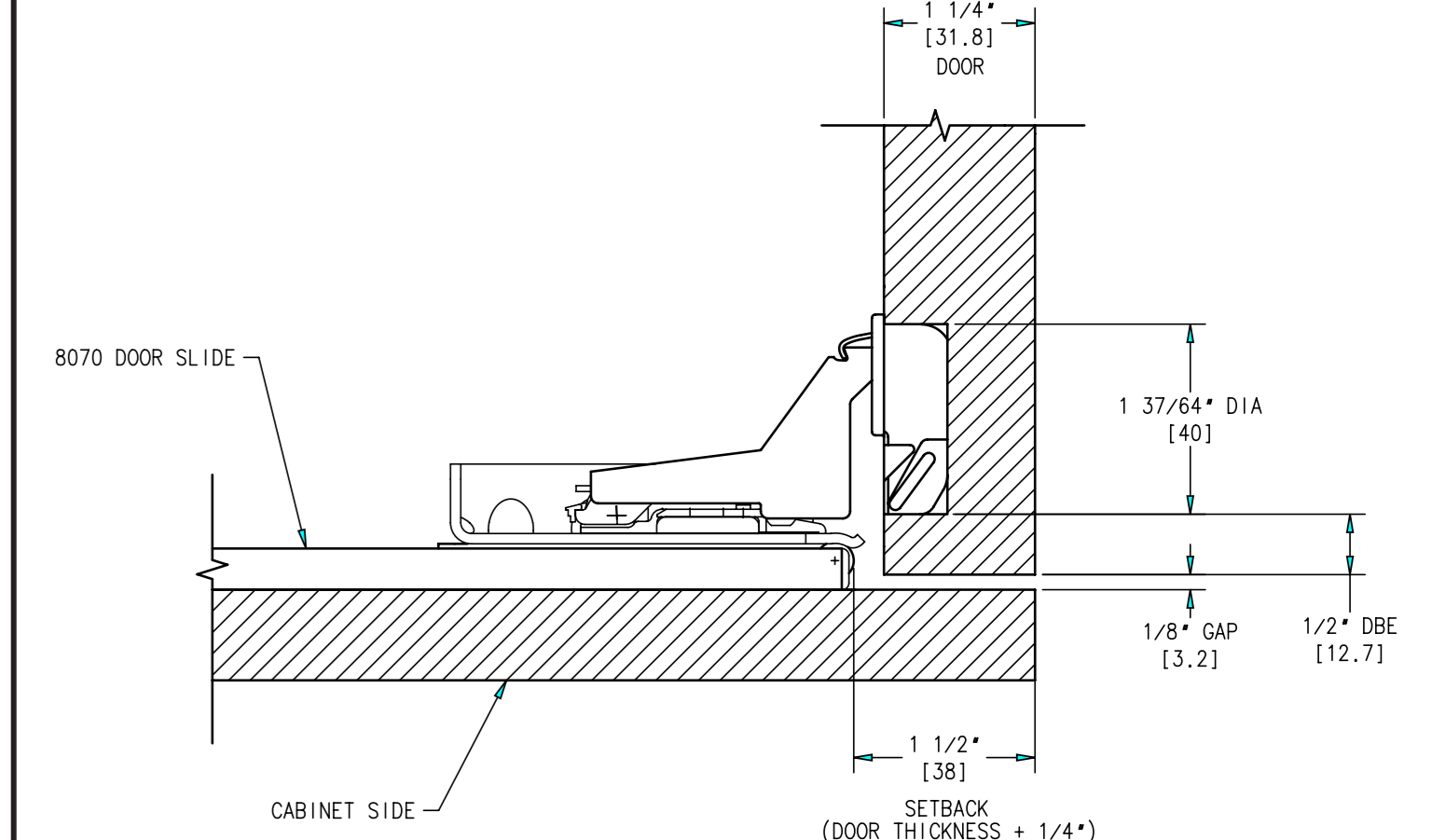

FACE-FRAME APPLICATIONS

Standard Inset

Face-frame applications with 3/4" thick door.

- 8080 HKEZSEB (Black)

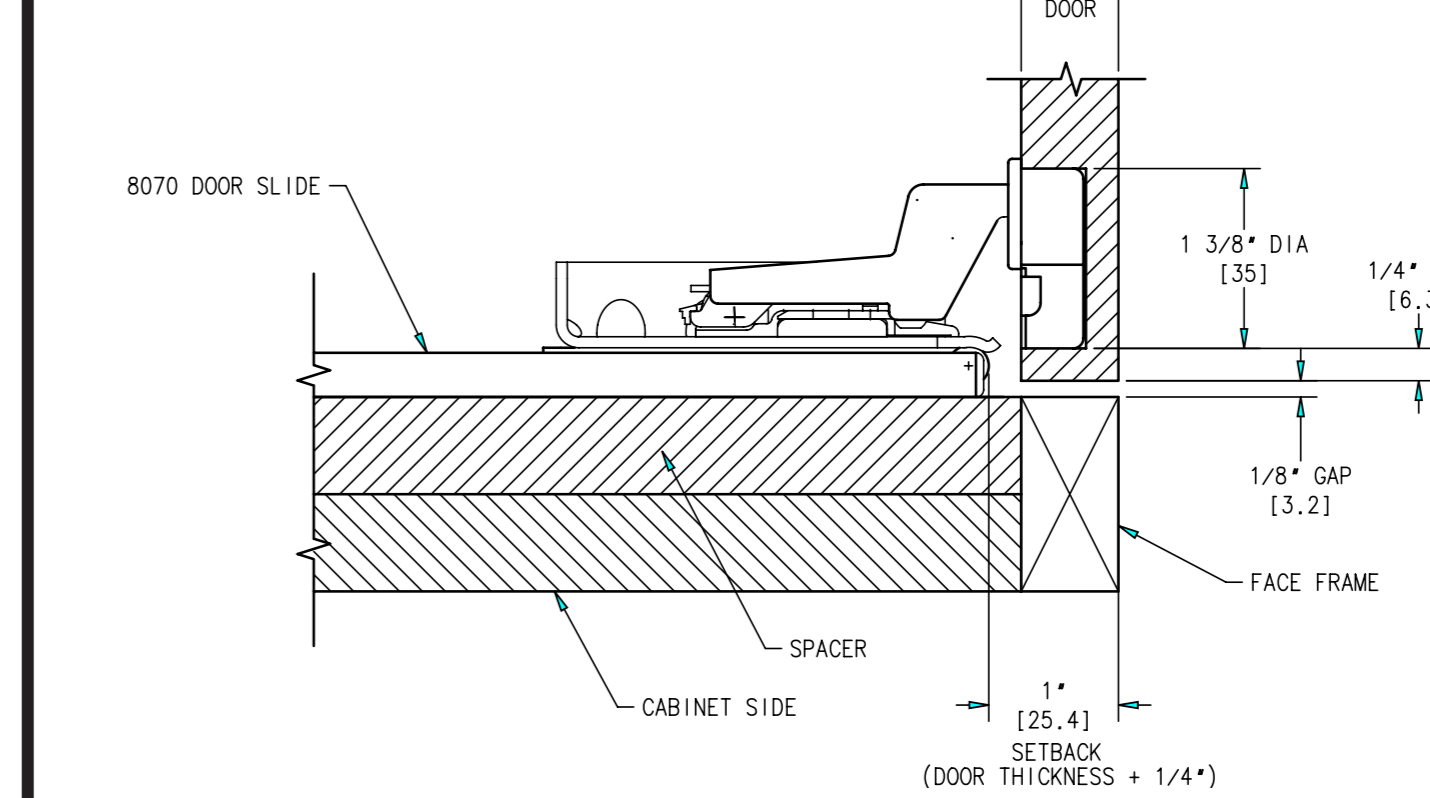

Partial Overlay

Face-frame applications with 3/4" thick door. Maximum overlay with full hinge adjustment is 13/32".

- 8080 HKEZLEB (Black)

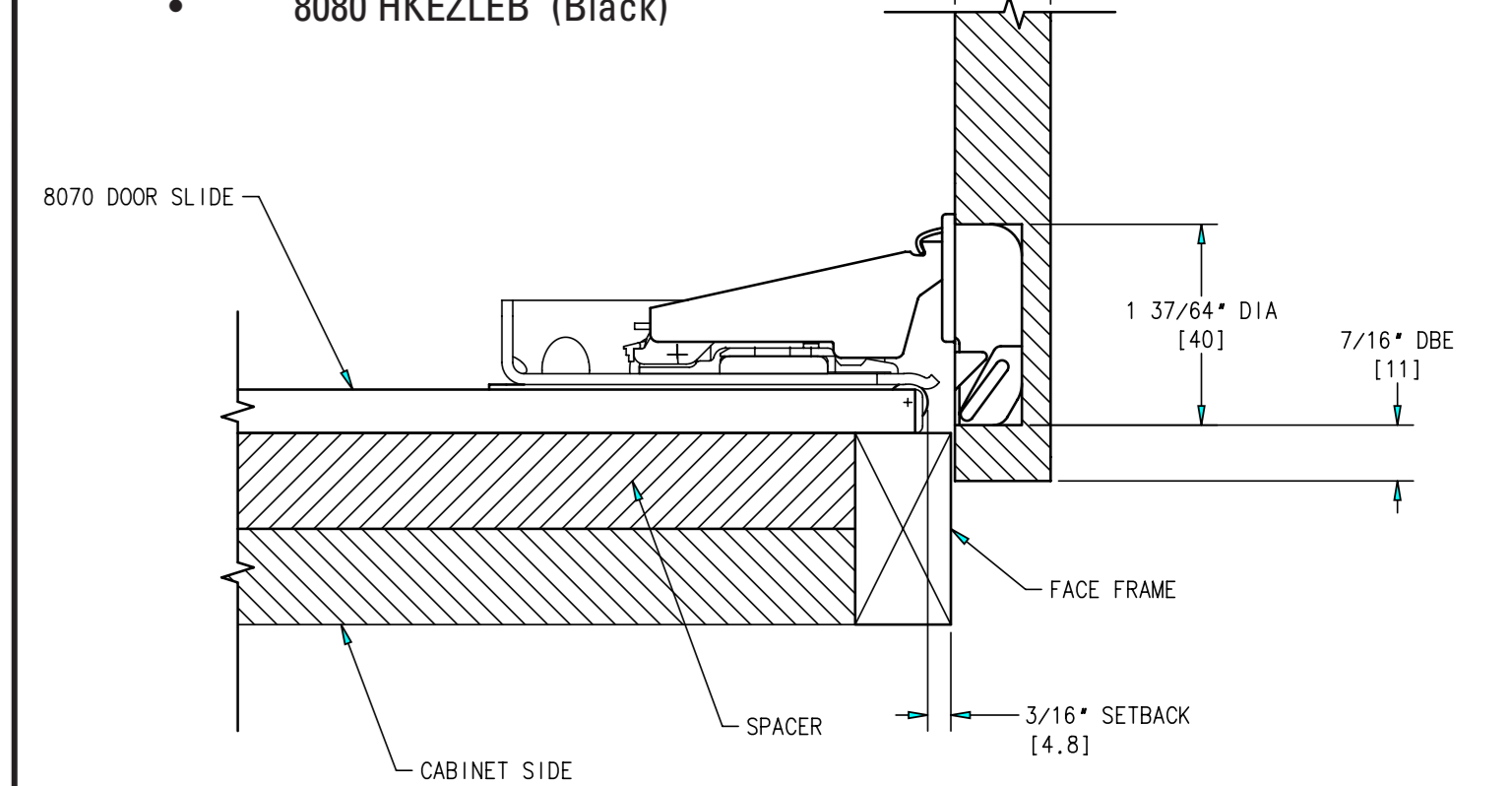

figure 5

8070EZ Series Pocket Door Slides

SPECIFICATIONS:

- 30-pound maximum per door.
- Designed to mount to side of case for pocket door mode. For the flipper mode, door retracts inside of case.
- Maximum door dimension of 24" x 42".
- Self-closing three-way adjustable geometric door hinge with single lever disconnect feature.
- Precision steel ball bearings.
- Large follower strip mounting plate for rigidity and installation ease.

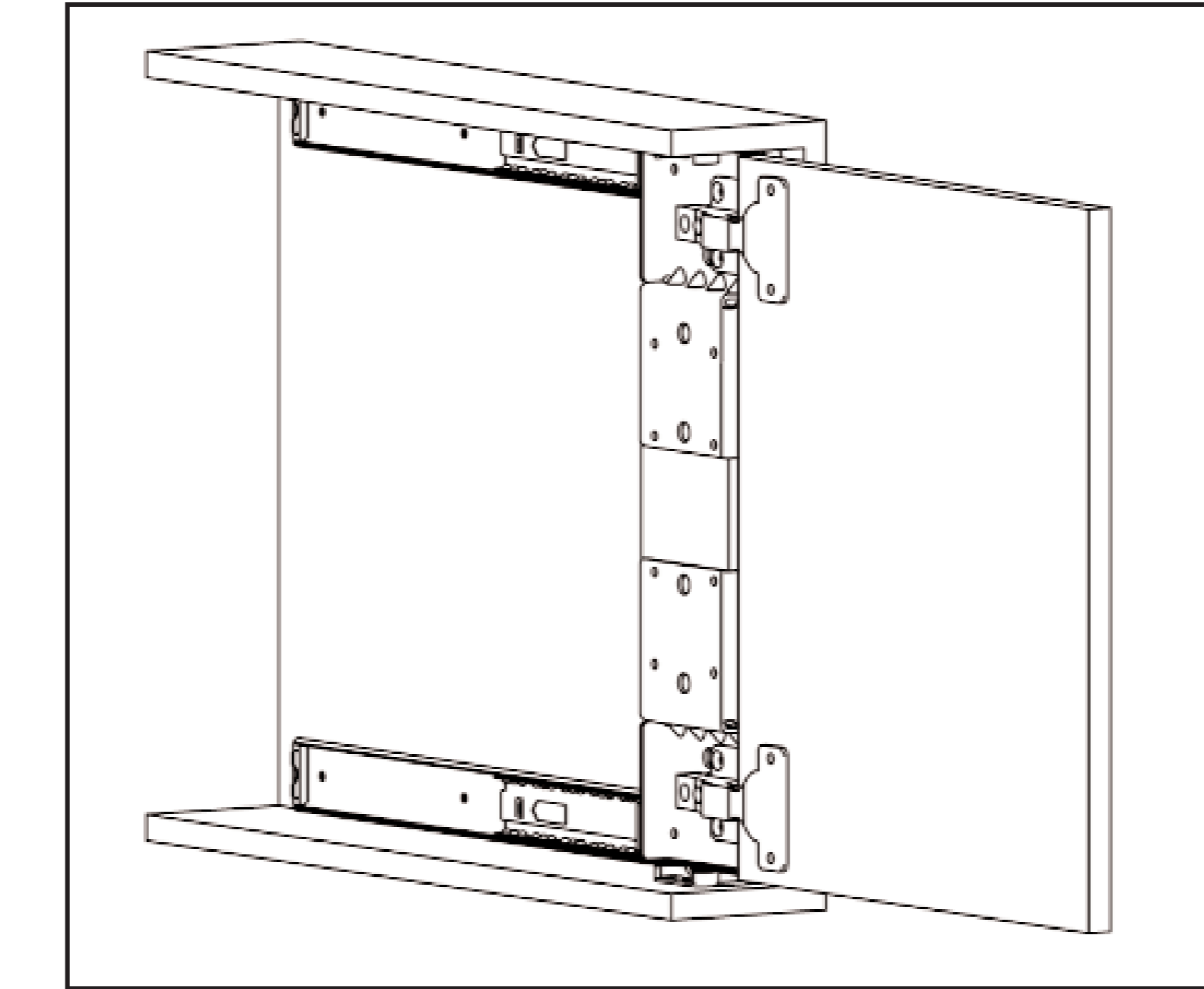
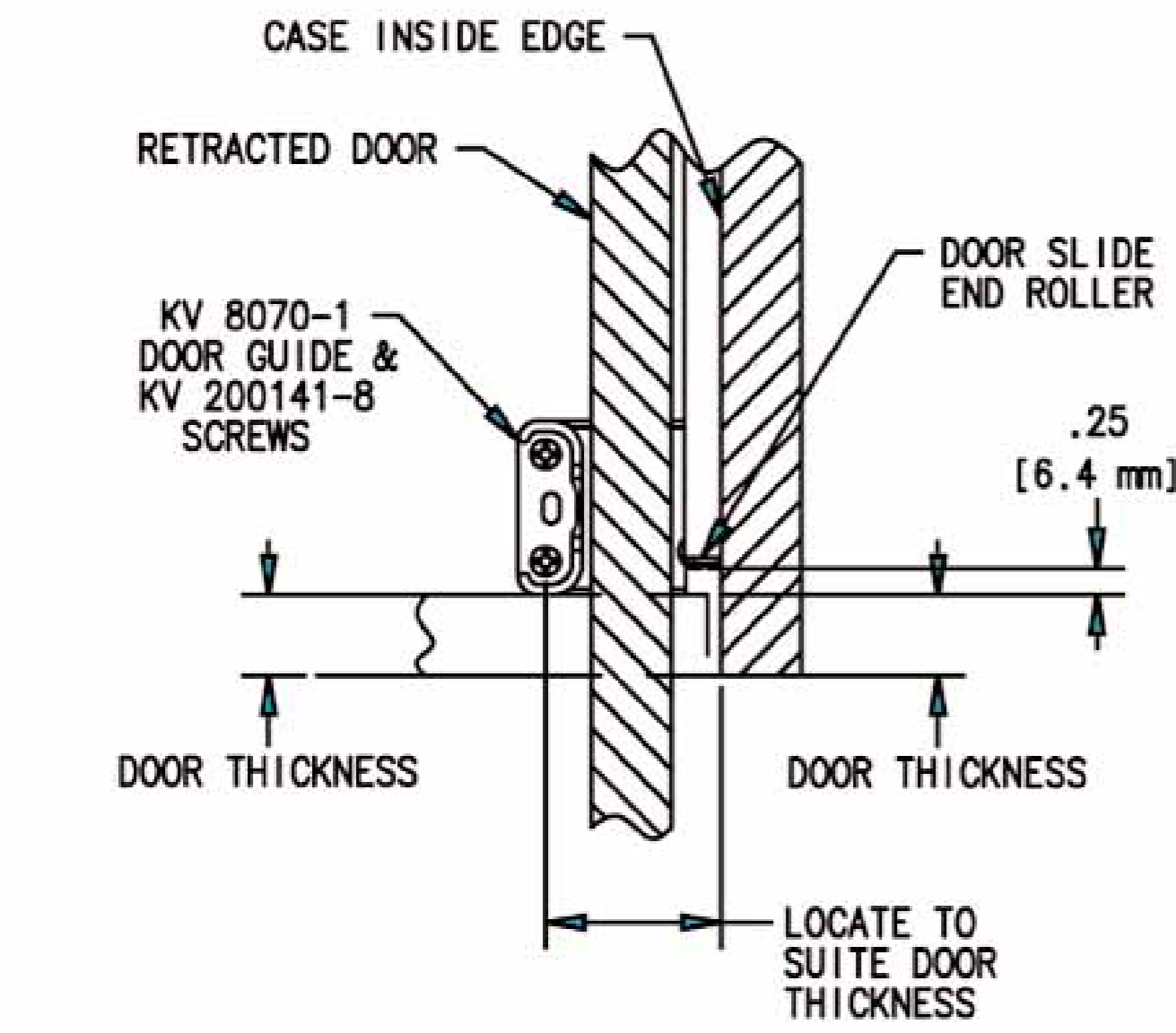

figure 6



DOOR GUIDE ROLLER INSTALLATION

figure 7

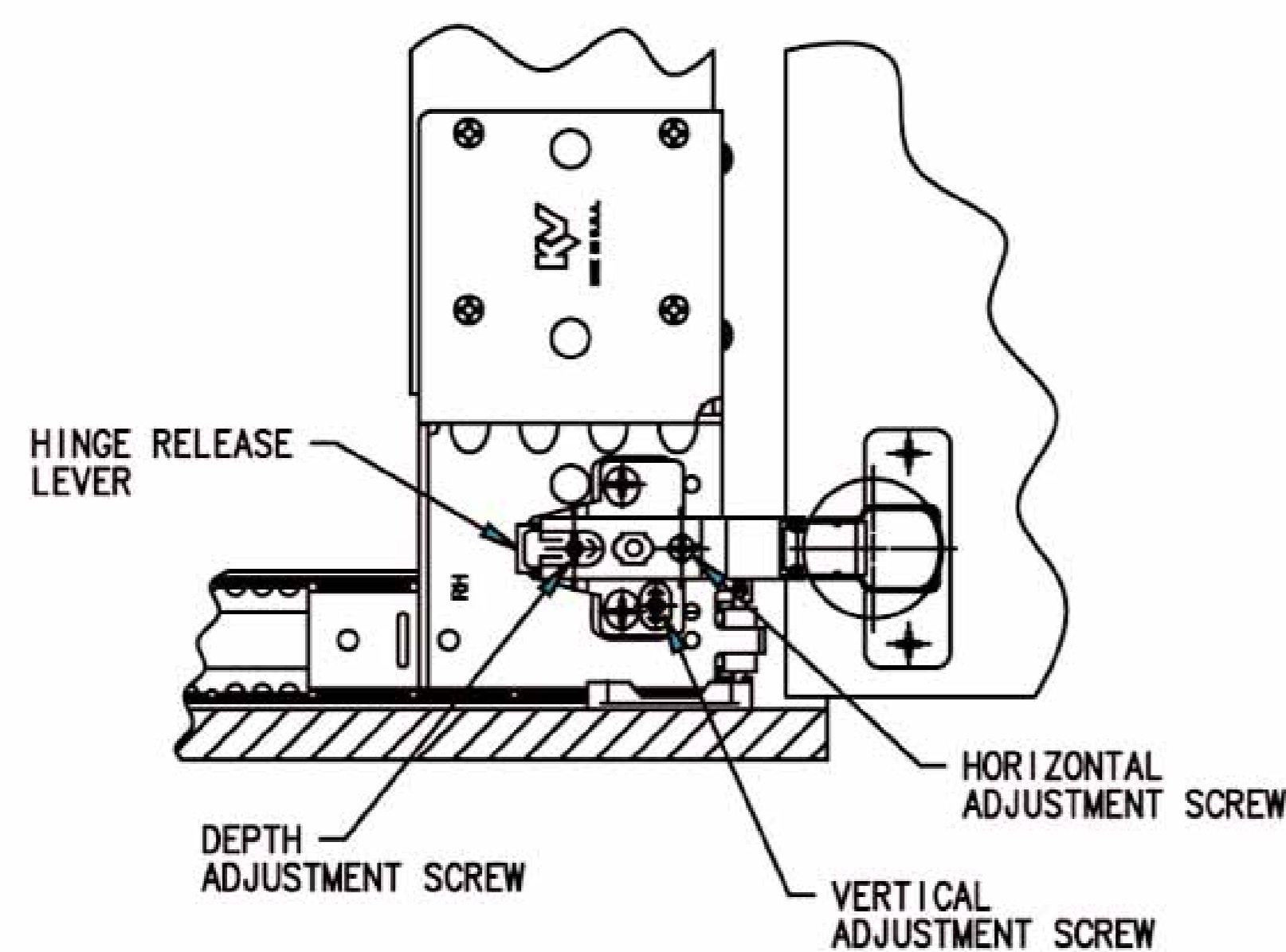
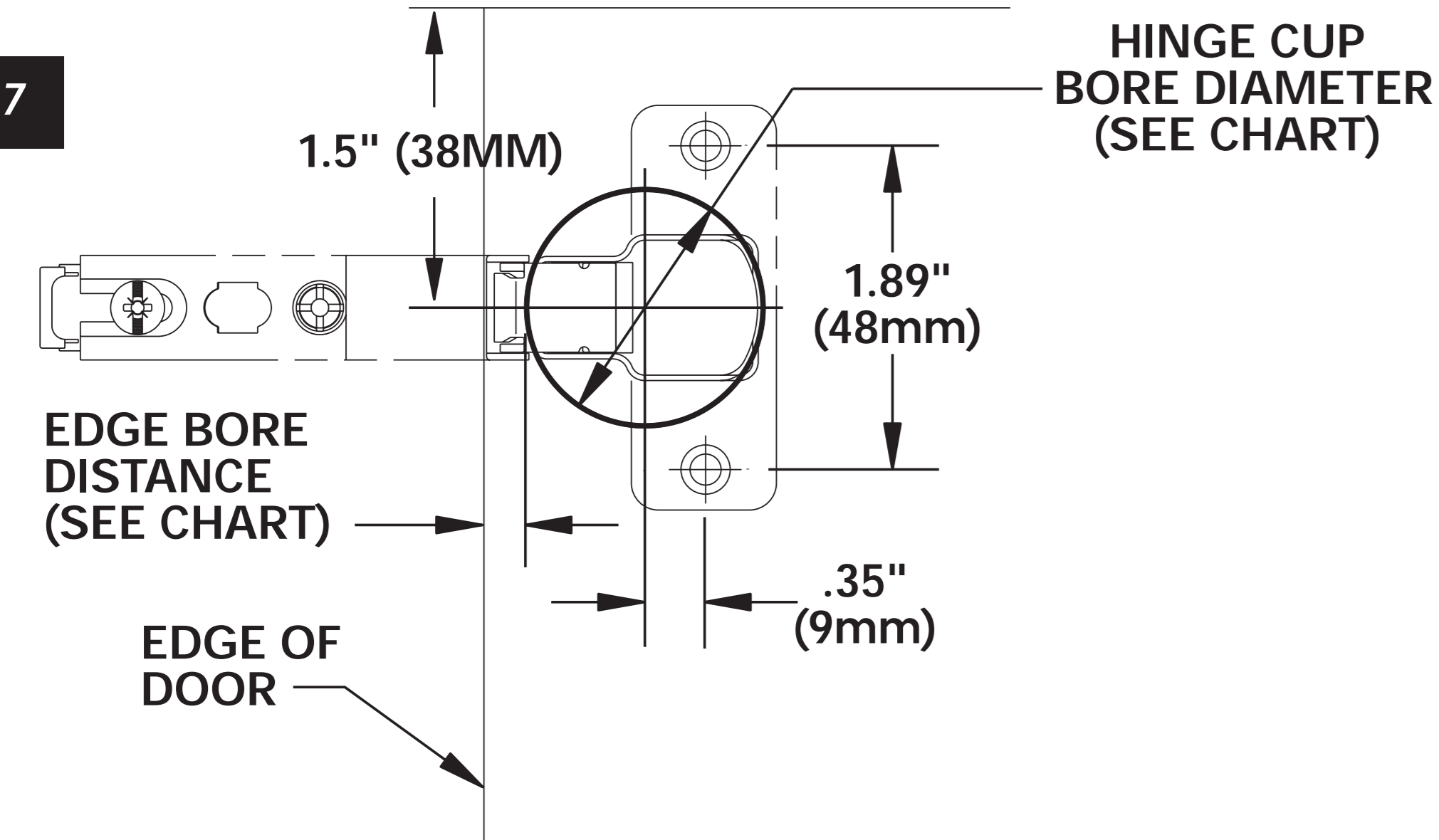

figure 8

HINGE ADJUSTMENT

Limited Lifetime Warranty

Knape & Vogt Manufacturing Company guarantees its drawer slides and builder's hardware products against failure or defects for so long as the purchaser or end user owns them. This warranty is void if any damage to the product is due to misuse, neglect, accident, improper installation or any uses contrary to the instructions accompanying the product. This warranty covers the cost of the defective part and not the cost of removal, installation or other incidental charges. The foregoing are the purchaser's exclusive remedies. Knape & Vogt Manufacturing Company assumes no liability for special or consequential damages.

Replacement product may be obtained by returning the product, transportation charges prepaid, together with a receipt of purchase or other documents acknowledging the sale of the product to the Knape & Vogt Manufacturing Company, Attention: Customer Service Department.

The warranty set forth above is in lieu of any other warranties, express or implied, including warranties of merchantability and fitness for use.



Knape & Vogt Manufacturing Company
2700 Oak Industrial Drive NE
Grand Rapids, MI 49505
800.253.1561 • 616.459.3311 • fax 616.459.3290
www.kv.com

chart 1

PART NUMBER	L	SLIDE TRAVEL	APPROX. DOOR CONCEAL	APPROX. CABINET DEPTH
8070PEZ EB 12	12-1/8"	7.46"	8"	12-3/8"
8071PEZ EB 12	[308.0mm]	[189.5mm]	[203.2mm]	[314.3mm]
8072PEZ EB 12				
8070PEZ EB 14	14-1/8"	9.46"	10"	14-3/8"
8071PEZ EB 14	[358.8mm]	[240.3mm]	[254.0mm]	[365.1mm]
8072PEZ EB 14				
8070PEZ EB 16	16-1/8"	11.46"	12"	16-3/8"
8071PEZ EB 16	[409.6mm]	[291.1mm]	[304.8mm]	[415.9mm]
8072PEZ EB 16				
8070PEZ EB 18	18-1/8"	13.46"	14"	18-3/8"
8071PEZ EB 18	[460.4mm]	[341.9mm]	[355.6mm]	[466.7mm]
8072PEZ EB 18				
8070PEZ EB 20	20-1/8"	15.46"	16"	20-3/8"
8071PEZ EB 20	[511.2mm]	[392.9mm]	[406.4mm]	[517.5mm]
8072PEZ EB 20				
8070PEZ EB 22	22-1/8"	17.46"	18"	22-3/8"
8071PEZ EB 22	[562.0mm]	[443.5mm]	[457.2mm]	[568.3mm]
8072PEZ EB 22				
8070PEZ EB 24	24-1/8"	19.46"	20"	24-3/8"
8071PEZ EB 24	[612.8mm]	[494.3mm]	[508.0mm]	[619.1mm]
8072PEZ EB 24				
8070PEZ EB 26	26-1/8"	21.46"	22"	26-3/8"
8071PEZ EB 26	[663.6mm]	[545.1mm]	[558.8mm]	[669.9mm]
8072PEZ EB 26				
8070PEZ EB 28	28-1/8"	23.46"	24"	28-3/8"
8071PEZ EB 28	[714.4mm]	[595.9mm]	[609.6mm]	[720.7mm]
8072PEZ EB 28				

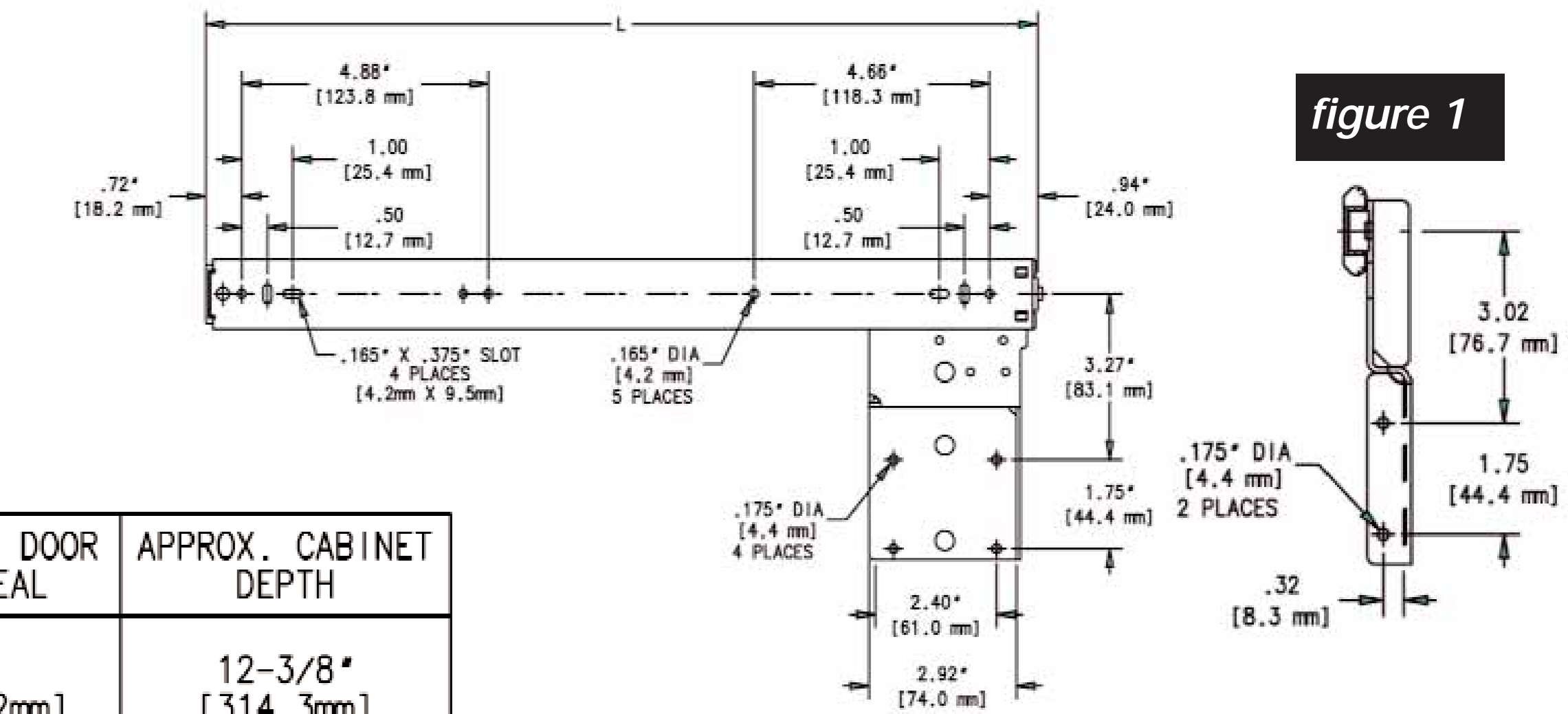

figure 1

MOUNTING HOLE DIMENSIONS

READ INSTRUCTIONS FIRST!

These instructions show how to install the KV 8070 Series Pocket Door Slide. Please note that improper installation may void the Knape & Vogt Limited Lifetime Warranty.

If you have questions or need additional information, please contact Knape & Vogt customer service (800) 253-1561.