

# Klok & XL Klok

U.S. Pat. 6.584.645

Grande robustezza e capacità di carico  
 Meccanismo di precisione che assicura leggerezza e fluidità di movimento, con arresto dell'anta in qualsiasi posizione

Applicabile per ante in legno o con telaio in alluminio, frenato in apertura ed in chiusura (1 e 2)

Disponibile in due versioni: Klok per ante leggere e **XL Klok** per ante di dimensioni maggiori

Prodotto testato a 100.000 cicli

Assoluta garanzia di durata

High strength and load capacity

Precision mechanism to ensure light and smooth action with flap held at any angle

Can be mounted on wooden and aluminium frame flap doors upwards and downwards (1 and 2)

Available in two versions: Klok for light door and **XL Klok** for big doors

Tested at 100.000 cycles

Guaranteed durability

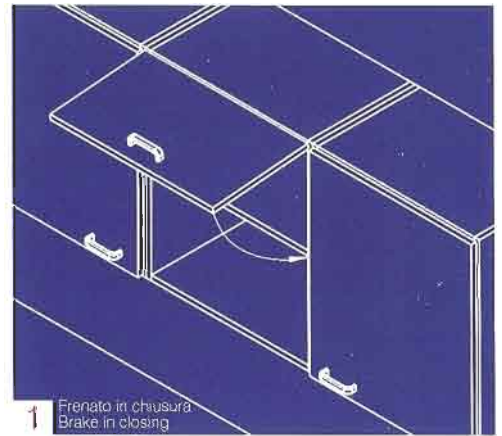

Gamma disponibile Range available	Klok		XL Klok	
	Frenato in chiusura Brake in closing	Frenato in apertura Brake in opening	Frenato in chiusura Brake in closing	Frenato in apertura Brake in opening
Con piastrine di fissaggio fornite separatamente With fixing brackets supplied separately				
Con piastrine di fissaggio rivettate With riveted fixing brackets				



Klok - Frenato in chiusura  
Klok - Brake in closing

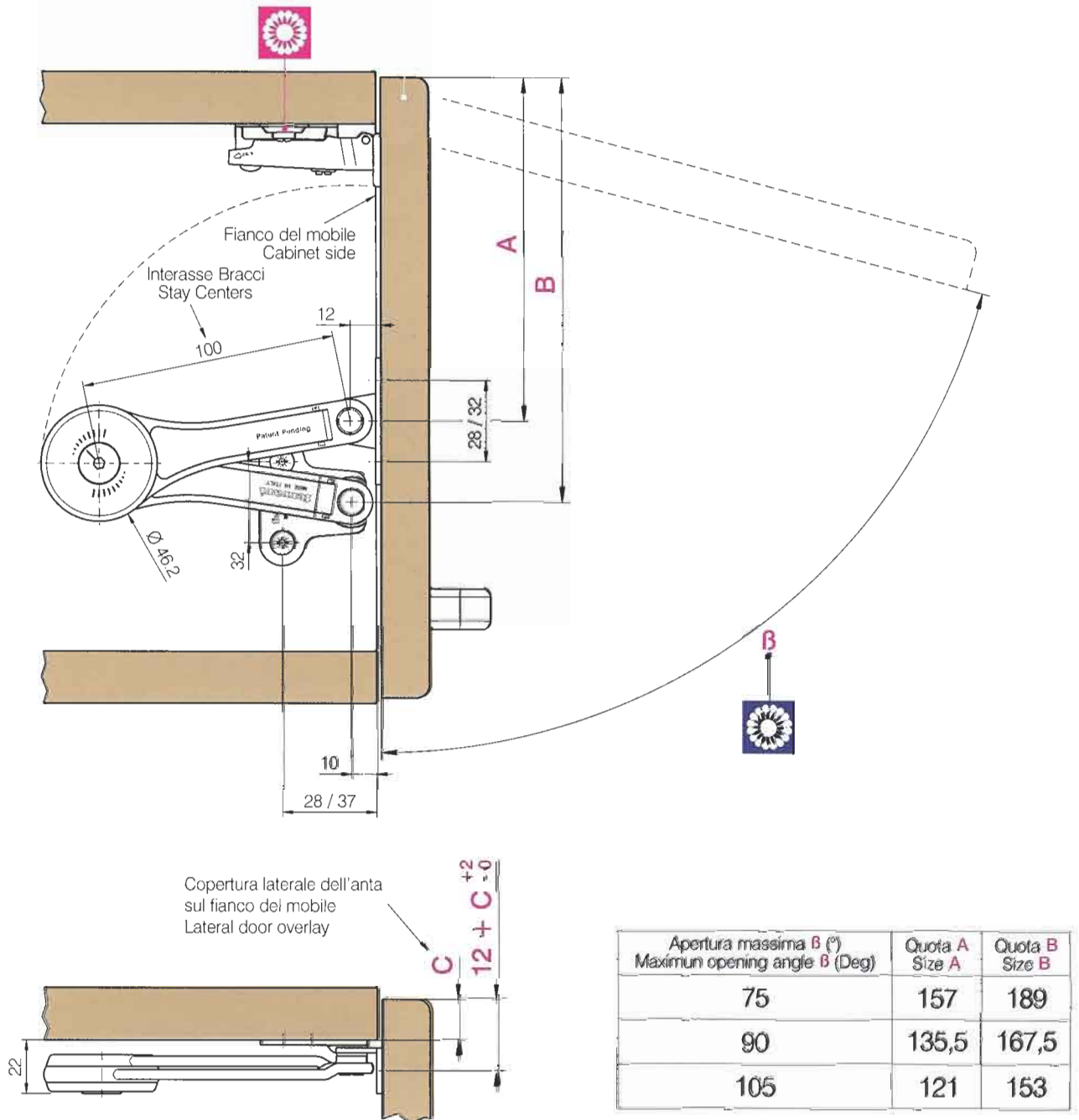

Montaggio klok su anta con cornice  
Klok mounting on the face frame door

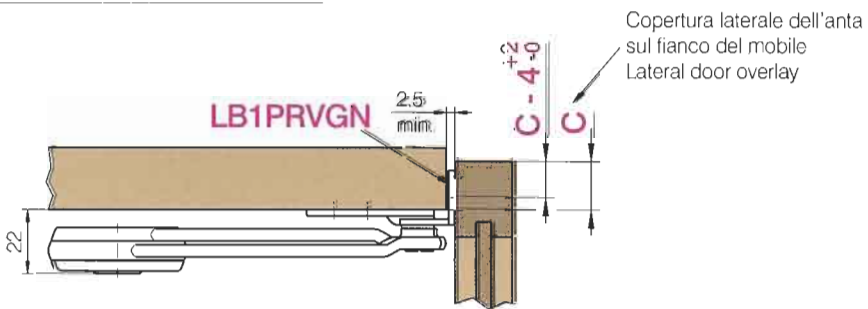



Klok - Frenato in apertura  
Klok - Brake in opening

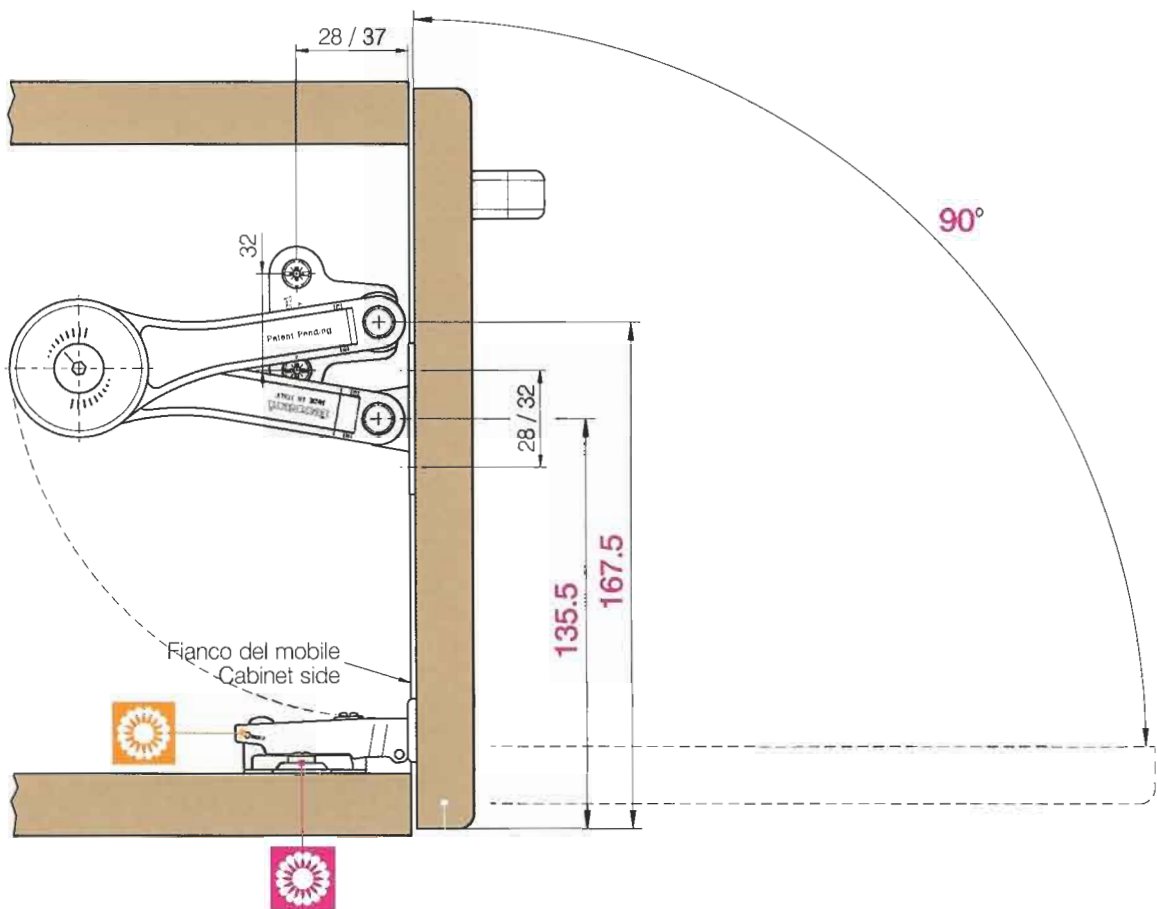

Per l'apertura massima a  $105^\circ$  utilizzare esclusivamente cerniere con apertura adeguata.  
For maximum opening to  $105^\circ$  to use only the hinges with adapted opening.

Per ante di larghezza superiore a 600 mm è consigliato l'uso di 3 cerniere.  
For doors with width hinger than 600 mm we suggest to use three hinges.



Si consiglia l'applicazione di basi con euroviti.  
We suggest to use the mounting plates with euroscrews.



Nel caso di utilizzo di cerniere Mini (con molla debole), rivolgersi al commerciale Ferrari.  
For Mini hinges or hinges with too soft spring, we suggest to contact our Commercial Dept.



**XL Klok - Frenato in chiusura**  
**XL Klok - Brake in closing**

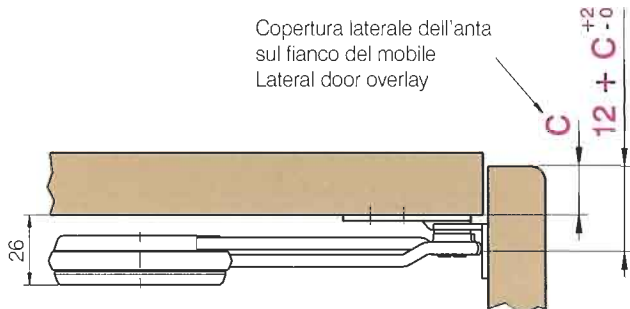
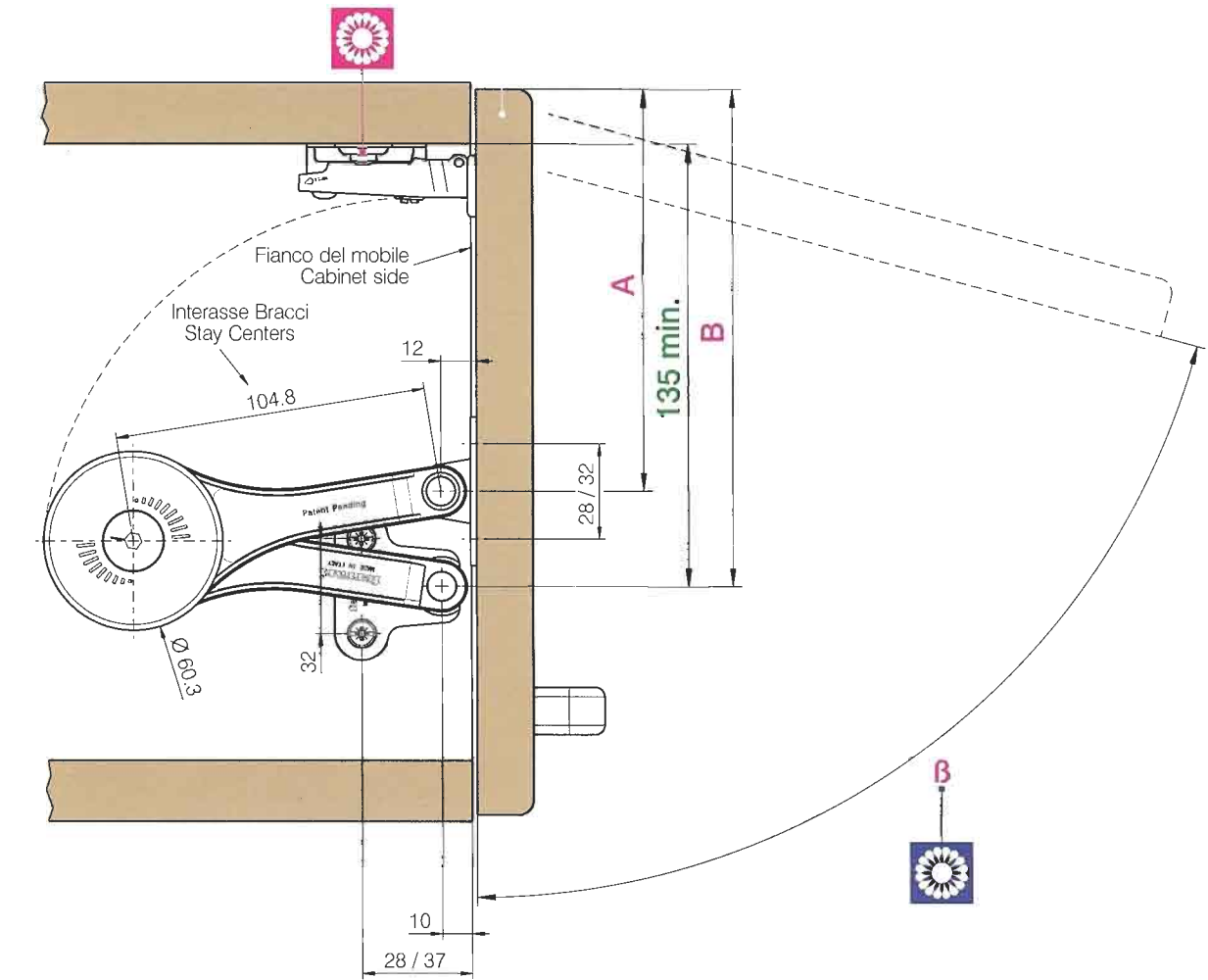

Apertura massima $\beta$ (°) Maximum opening angle $\beta$ (Deg)	Quota A Size A	Quota B Size B
75	157	189
90	135,5	167,5
105	121	153

**Montaggio XL klok su anta con cornice**  
**XL Klok mounting on the face frame door**

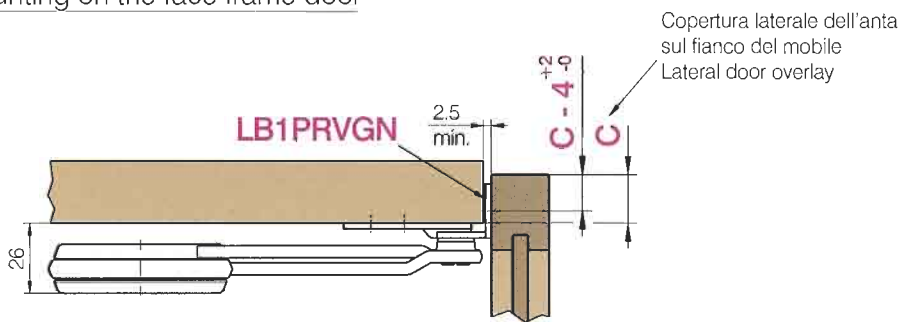



XL Klok - Frenato in apertura  
 XL Klok - Brake in opening

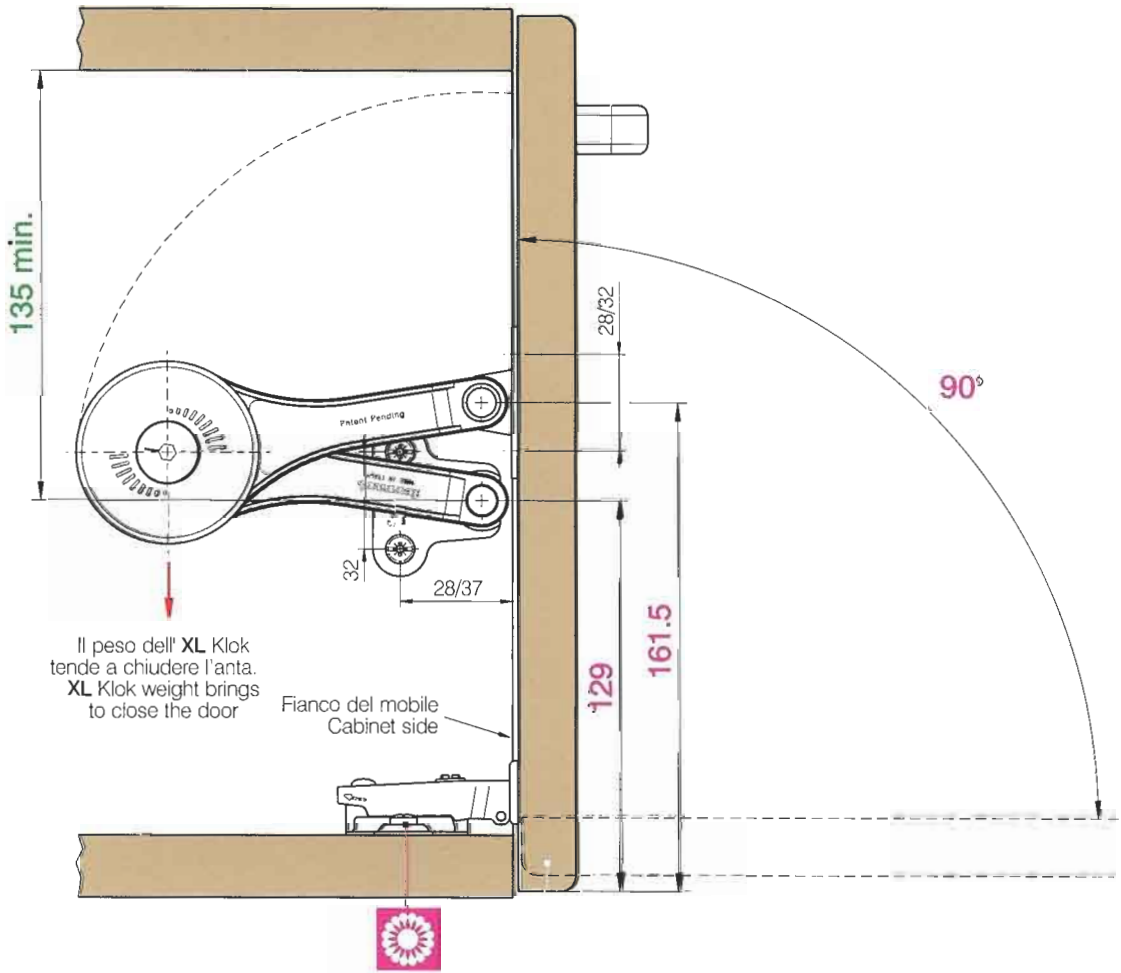

Per l'apertura massima a 105° utilizzare esclusivamente cerniere con apertura adeguata.  
 For maximum opening to 105 deg. to use only the hinges with adapted opening.

Per ante di larghezza superiore a 600 mm è consigliato l'uso di 3 cerniere.  
 For doors with width hinger than 600 mm we suggest to use three hinges.



Si consiglia l'applicazione di basi con euroviti.  
 We suggest to use the mounting plates with euroscrews.



Montaggio Klok con piastrine fornite separatamente  
Klok mounting with fixing brackets supplied separately

Montaggio Klok e XL Klok rivettati  
Mounting of Klok and XL Klok riveted

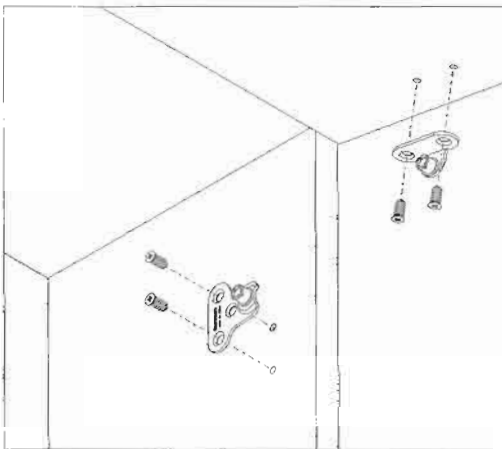

**1**  
Avvitare al mobile le piastrine di fissaggio.  
Screw on fixing brackets to cabinet and flap.

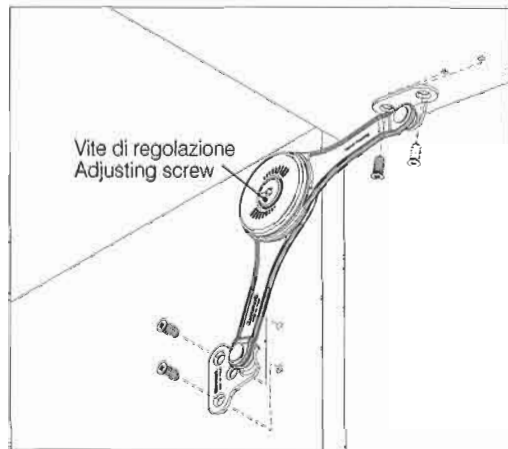

**1**  
Fissare il freno rivolgendo sempre la vite di regolazione all'interno del mobile.  
Fix always the brake leaving the adjusting screw always inside the cabinet.

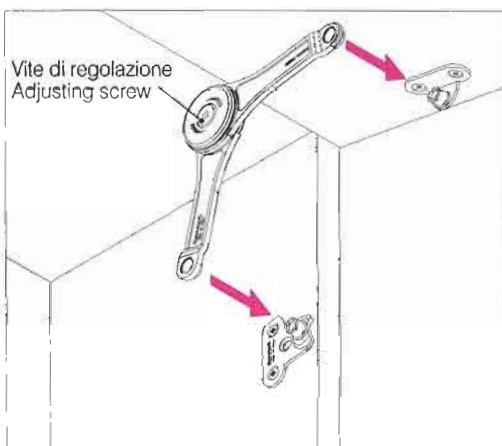

**2**  
Inserire Klok a pressione sulle piastrine di fissaggio lasciando sempre la vite di regolazione all'interno del mobile.  
Click on Klok on fixing brackets to mount it leaving the adjusting screw always inside the cabinet.

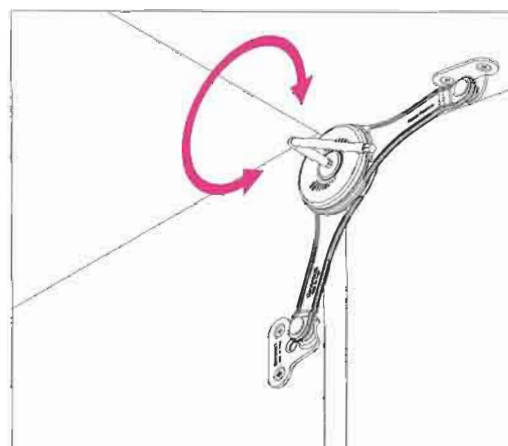

**2**  
Modulare con chiave esagonale la forza della frizione secondo le dimensioni e il peso dell'anta, usando l'apposita vite di regolazione.  
Adjust with allen key friction force according to flap door dimension and weight, using the adjusting screw.

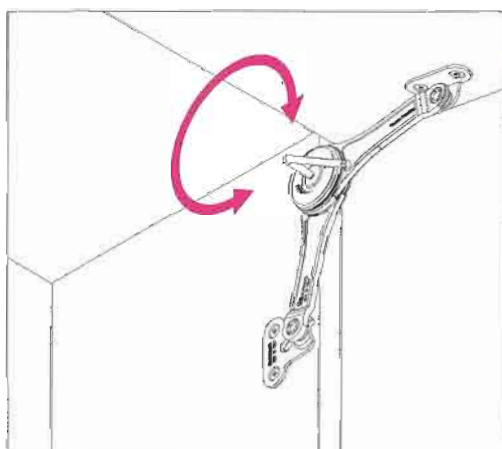
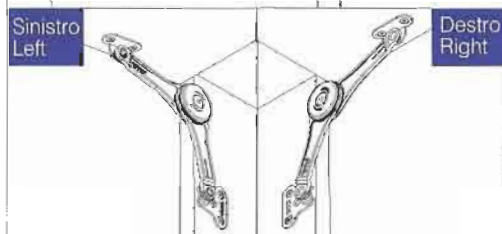

**3**  
Modulare con chiave esagonale la forza della frizione secondo le dimensioni e il peso dell'anta usando l'apposita vite di regolazione.  
Adjust with allen key friction force according to flap door dimension and weight using the adjusting screw.



Klok con piastrine di fissaggio fornite separatamente  
Klok with fixing brackets supplied separately

Codice  
Code

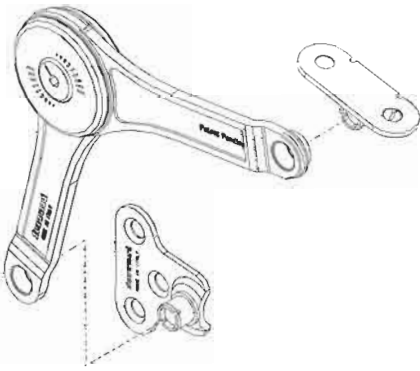

Frenato in apertura  
Brake in opening

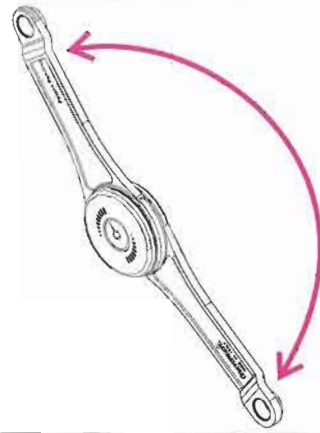
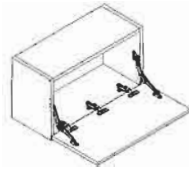

LE1GA00

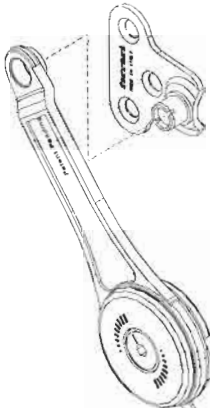

Frenato in chiusura  
Brake in closing



LE1GC00

Piastrine di fissaggio al fianco  
Side fixing brackets

Interasse di foratura  
Drilling distance



37x32

LB1F7VGN



28x32

LB1F8VGN

Piastrine di fissaggio all'anta  
Door fixing brackets



32

LB1P0VGN



28

LB1P2VGN



32  
invertita  
reversed

LB1PRVGN

17 Per telaio in alluminio  
For aluminium frame

Fianco del mobile  
Cabinet side

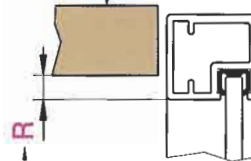

Rientro del profilo in alluminio all'interno della luce del mobile  
Aluminium frame protrusion into the cabinet.

R = 0

LB100AGN

R = 1

LB110AGN

R = 2

LB120AGN

R = 3

LB130AGN

R = 4

LB140AGN

R = 5

LB150AGN

R = 6

LB160AGN

R = 7

LB170AGN

R = 8

LB180AGN

Opzionale  
Optional



Chiave esagonale da 4 mm per regolazione  
4 mm allen key for adjustment

Cod. CH0102B1

**Klok rivettato - Frenato in chiusura**  
**Riveted Klok - Brake in closing**

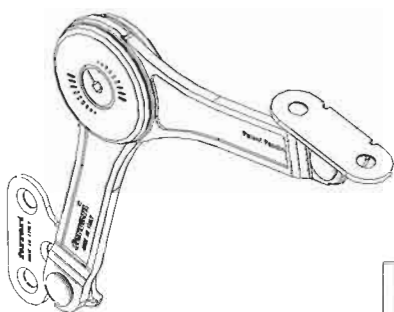

Piastrine di fissaggio al fianco  
**Cabinet fixing brackets**

Tipo di montaggio  
 Mounting type

**37x32**

**28x32**

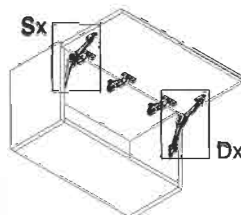

Interasse di foratura  
 Drilling distance

**32**



Montaggio a destra  
 Right mounting

LE1GC51

LE1GCA1

Montaggio a sinistra  
 Left mounting

**LE1GC52**

LE1GCA2

**28**



Montaggio a destra  
 Right mounting

LE1GC63

LE1GCB3

Montaggio a sinistra  
 Left mounting

LE1GC62

LE1GCB2

**32** Invertita  
 Reversed



Montaggio a destra  
 Right mounting

LE1GC59

LE1GCA9

Montaggio a sinistra  
 Left mounting

LE1GC58

LE1GCA8

**17** Per telaio in alluminio  
 For aluminium frame



Montaggio a destra  
 Right mounting

**R = 0**

LE1GC67

LE1GCB7

**R = 1**

LE1GC71

LE1GCC1

**R = 2**

LE1GC75

LE1GCC5

**R = 3**

LE1GC53

LE1GCA3

**R = 4**

LE1GC83

LE1GCD3

**R = 5**

LE1GC87

LE1GCD7

**R = 6**

LE1GC91

LE1GCE1

**R = 7**

LE1GC95

LE1GCE5

**R = 8**

**LE1GC99**

**LE1GCE9**

Montaggio a sinistra  
 Left mounting

**R = 0**

LE1GC66

LE1GCB6

**R = 1**

LE1GC70

LE1GCC0

**R = 2**

LE1GC74

LE1GCC4

**R = 3**

LE1GC78

LE1GCC8

**R = 4**

LE1GC82

LE1GCD2

**R = 5**

LE1GC86

LE1GCD6

**R = 6**

LE1GC90

LE1GCE0

**R = 7**

LE1GC94

LE1GCE4

**R = 8**

LE1GC98

LE1GCE8

Piastrine di fissaggio all'anta  
 Door fixing brackets

Anta con telaio in alluminio  
 Aluminium flap door

Fianco del mobile  
 Cabinet side

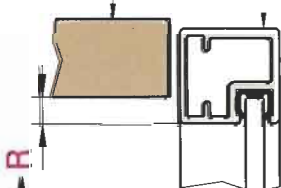

**R** = Rientro del profilo in alluminio  
 all'interno della luce del mobile  
 Aluminium frame protrusion into  
 the cabinet

Opzionale  
 Optional



Chiave esagonale da  
 4 mm per regolazione  
 4 mm allen key for  
 adjustment

Cod.

**CH0102B1**

**ferrari**

# Codici Klok rivettato Riveted Klok codes



Klok rivettato - Frenato in apertura  
Riveted Klok - Brake in opening

Piastrine di fissaggio al fianco  
Cabinet fixing brackets

Tipo di montaggio  
Mounting type

37x32

28x32

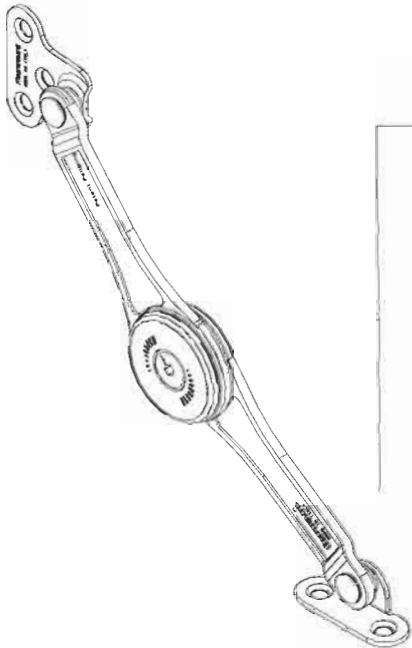
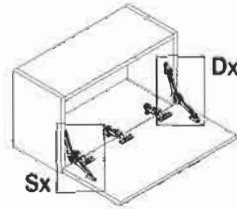

Interasse di foratura  
Drilling distance

32



Montaggio a destra  
Right mounting

LE1GA55

LE1GAA5

Montaggio a sinistra  
Left mounting

LE1GA54

LE1GAA4

28



Montaggio a destra  
Right mounting

LE1GA61

LE1GAB1

Montaggio a sinistra  
Left mounting

LE1GA60

LE1GAB0

32

Invertita  
Reversed



Montaggio a destra  
Right mounting

LE1GA57

LE1GAA7

Montaggio a sinistra  
Left mounting

LE1GA56

LE1GAA6

17

Per telaio in alluminio  
For aluminium frame



Montaggio a destra  
Right mounting

R = 0

LE1GA65

LE1GAB5

R = 1

LE1GA69

LE1GAB9

R = 2

LE1GA73

LE1GAC3

R = 3

LE1GA77

LE1GAC7

R = 4

LE1GA81

LE1GAD1

R = 5

LE1GA85

LE1GAD5

R = 6

LE1GA89

LE1GAD9

R = 7

LE1GA93

LE1GAE3

R = 8

LE1GA97

LE1GAE7

Montaggio a sinistra  
Left mounting

R = 0

LE1GA64

LE1GAB4

R = 1

LE1GA68

LE1GAB8

R = 2

LE1GA72

LE1GAC2

R = 3

LE1GA76

LE1GAC6

R = 4

LE1GA80

LE1GAD0

R = 5

LE1GA84

LE1GAD4

R = 6

LE1GA88

LE1GAD8

R = 7

LE1GA92

LE1GAE2

R = 8

LE1GA96

LE1GAE6

Piastrine di fissaggio all'anta  
Door fixing brackets

Anta con telaio in alluminio  
Aluminium flap door

Fianco del mobile  
Cabinet side

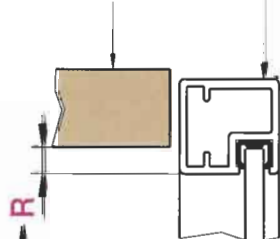

R = Rientro del profilo in alluminio  
all'interno della luce del mobile  
Aluminium frame protrusion into  
the cabinet

Opzionale  
Optional



Chiave esagonale da  
4 mm per regolazione  
4 mm allen key for  
adjustment

Cod.

CH0102B1

**XL Klok rivettato - Frenato in chiusura**  
**Riveted XL Klok - Brake in closing**

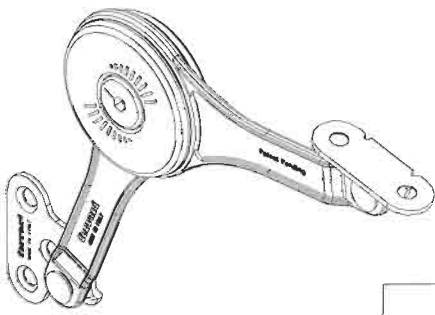

**Piastrine di fissaggio al fianco**  
**Cabinet fixing brackets**

Tipo di montaggio  
 Mounting type

**37x32**

**28x32**

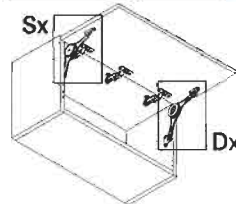

Interasse di foratura  
 Drilling distance

**32**



Montaggio a destra  
 Right mounting  
 Montaggio a sinistra  
 Left mounting

LP1GC51

LP1GCA1

LP1GC52

LP1GCA2

**28**



Montaggio a destra  
 Right mounting  
 Montaggio a sinistra  
 Left mounting

LP1GC63

LP1GCB3

LP1GC62

LP1GCB2

**32** Invertita  
 Reversed



Montaggio a destra  
 Right mounting  
 Montaggio a sinistra  
 Left mounting

LP1GC59

LP1GCA9

LP1GC58

LP1GCA8

**17** Per telaio in alluminio.  
 For aluminium frame



Montaggio a destra  
 Right mounting

**R = 0**

LP1GC67

LP1GCB7

**R = 1**

LP1GC71

LP1GCC1

**R = 2**

LP1GC75

LP1GCC5

**R = 3**

LP1GC53

LP1GCA3

**R = 4**

LP1GC83

LP1GCD3

**R = 5**

LP1GC87

LP1GCD7

**R = 6**

LP1GC91

LP1GCE1

**R = 7**

LP1GC95

LP1GCE5

**R = 8**

LP1GC99

LP1GCE9

Montaggio a sinistra  
 Left mounting

**R = 0**

LP1GC66

LP1GCB6

**R = 1**

LP1GC70

LP1GCC0

**R = 2**

LP1GC74

LP1GCC4

**R = 3**

LP1GC78

LP1GCC8

**R = 4**

LP1GC82

LP1GCD2

**R = 5**

LP1GC86

LP1GCD6

**R = 6**

LP1GC90

LP1GCE0

**R = 7**

LP1GC94

LP1GCE4

**R = 8**

LP1GC98

LP1GCE8

Piastrine di fissaggio all'anta  
 Door fixing brackets

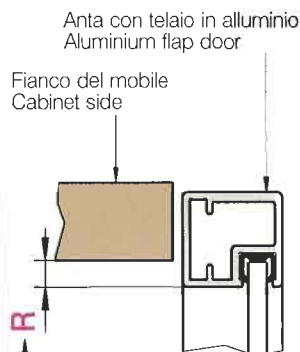

**R** = Rientro del profilo in alluminio all'interno della luce del mobile  
 Aluminium frame protrusion into the cabinet

Opzionale  
 Optional



Chiave esagonale da 5 mm per regolazione  
 5 mm allen key for adjustment

Cod. **CH2202B1**

# Codici XL Klok rivettato Riveted XL Klok codes



**XL Klok rivettato - Frenato in apertura**  
Riveted XL Klok - Brake in opening

Piastrine di fissaggio al fianco  
Cabinet fixing brackets

Tipo di montaggio  
Mounting type

37x32

28x32

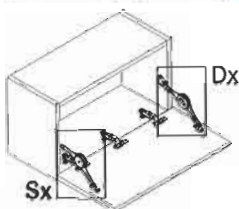

Interasse di foratura  
Drilling distance

32



Montaggio a destra  
Right mounting

LP1GA55

LP1GAA5

Montaggio a sinistra  
Left mounting

LP1GA54

LP1GAA4

28



Montaggio a destra  
Right mounting

LP1GA61

LP1GAB1

Montaggio a sinistra  
Left mounting

LP1GA60

LP1GAB0

32

Invertita  
Reversed



Montaggio a destra  
Right mounting

LP1GA57

LP1GAA7

Montaggio a sinistra  
Left mounting

LP1GA56

LP1GAA6

17

Per telaio in alluminio  
For aluminium frame



Montaggio a destra  
Right mounting

**R = 0**

LP1GA65

LP1GAB5

**R = 1**

**LP1GA69**

**LP1GAC9**

**R = 2**

LP1GA73

LP1GAC3

**R = 3**

**LP1GA77**

**LP1GAC7**

**R = 4**

LP1GA81

LP1GAD1

**R = 5**

LP1GA85

LP1GAD5

**R = 6**

LP1GA89

LP1GAD9

**R = 7**

LP1GA93

LP1GAE3

**R = 8**

**LP1GA97**

**LP1GAE7**

Montaggio a sinistra  
Left mounting

**R = 0**

LP1GA64

LP1GAB4

**R = 1**

LP1GA68

LP1GAC8

**R = 2**

LP1GA72

LP1GAC2

**R = 3**

LP1GA76

LP1GAC6

**R = 4**

LP1GA80

LP1GAD0

**R = 5**

LP1GA84

LP1GAD4

**R = 6**

LP1GA88

LP1GAD8

**R = 7**

LP1GA92

LP1GAE2

**R = 8**

LP1GA96

LP1GAE6



Piastrine di fissaggio all'anta  
Door fixing brackets

Anta con telaio in alluminio  
Aluminium flap door

Fianco del mobile  
Cabinet side

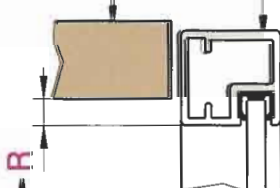

**R** = Rientro del profilo in alluminio  
all'interno della luce del mobile  
Aluminium frame protrusion into  
the cabinet

Opzionale  
Optional



Chiave esagonale da  
5 mm per regolazione  
5 mm allen key for  
adjustment

Cod.

**CH2202B1**