

# MURPHY®

WALL-BEDS HARDWARE INC.

## SUPREME Steel Bed Frame & Mechanism Models SBF-M and SBF INSTRUCTIONS



Established in 1975

**TOLL FREE 1-800-667-6336**

**PHONE: (604) 576-7880 • FAX: (604) 576-7867**

**E-mail: [info@murphybeds.com](mailto:info@murphybeds.com)**

**Websites: [murphybeds.com](http://murphybeds.com)**

## Contents

Package Contents & Equipment Checklist	3
Steel Bed Frame Cut List	5
Bed Cabinet Assembly Instructions	7
Securing Bed Cabinet	9
Installing Springs in Lift Mechanisms	10
Mounting Lift Mechanisms	12
Assembling the Bed Panel Unit	12
Installing the Bed Panel Unit	14
Attaching Handles & Legs	16
Installing Mattress & Mechanism Covers	17
EXTENDED LEG (+ 2 <sup>3/8</sup> ”) CUT LIST	17
LONG LEG (+ 6 <sup>1/8</sup> ”) CUT LIST	19

**MURPHY**<sup>®</sup>  
WALL-BEDS HARDWARE INC.

### CONGRATULATIONS

*on your purchase of Murphy Wall-Beds' hardware system, a patented bed frame system designed to International ISO 9002 standards to exceed both residential and commercial specifications.*

### Other Quality Products:

- Elite Aluminum Bed Systems
- Side-Tilt Models
- RTA Bed Cabinets & Side Cabinets
- Do-It-Yourself Mechanism Kit & Plans
- Extended legs
- Super Springs
- Wall Bed Frame & Foundation Hardware

## The Murphy Wall-Bed 25 year Guarantee for Supreme Steel Hardware Residential & Commercial Term

*Murphy Wall-Beds has been proudly doing business since 1975 under the names Tilt-Away Beds of America®, Tilt-Away Beds of Canada® and Murphy Wall-Beds of Canada®, which are all registered trademarks of Murphy Wall-Beds Hardware Inc. Copyright © by Murphy Wall-Beds Hardware Inc. These instructions are issued for the exclusive use of the original customer who purchased this product under any of the trademarks or Internet domains held by MURPHY WALL-BEDS HARDWARE INC. Using the component parts for or representing and selling this product as a 'MURPHY BED' in Canada or 'TILT-AWAY BED' world-wide may be interpreted as both trademark and copyright infringement. No part of this publication may be reproduced, stored in or introduced into a retrieval system, or transmitted, in any form or by any without prior written permission.*

## Mechanism & Steel Bed Frame Package Contents





Qty.	Item
2	Lift Mechanisms, Left/Right (L/R)
18	Lift Mechanism Springs
2	Lift Mechanism Safety Cover Plates (L/R)
2	End Frames
2	Side Frames
2	Stiffeners
1 pr.	Velcro Straps
1	13" Plastic Pipe
2	Legs, left & right with the following attached to each leg: 1 - 3/4" x 1 1/4" (OD) Lexan plastic washer 1 - 3/4" x 1 1/2" (OD) flat washer 1 - 5/16" x 1 1/2" (OD) flat washer 1 - 5/16" Nylock hexagon nut 1 Leg Crossbar with end-plugs attached

## Equipment Checklist

- 1/4" or 6 mm Allen key
- 72" bar clamps
- Countersink bit 5/16" - 5/8"
- Drill Bits 1/16", 1/8", 3/16" (5mm), 9/32" (7mm), 5/16"
- 36" Level
- Awl
- Pencil
- Screw Drivers – Slot & Phillips
- Small Tube of Black (or clear) Silicone
- Square
- Tape Measure (10' minimum)
- Wrench (adjustable or combination)
- Roll of 2" Plastic Packing Tape
- Hammer

## Bag #8 – Frames & Legs

### For Assembling Frames:

Qty.	Item
14	 3/16" x 1/2" trusshead screws
2	 3/16" x 1 1/4" flathead screws
16	 10 x 24 nylock nuts
4	 1" x 1" x 1 3/4" 4-hole corner brackets
2	 1/2" x 3/4" leg stops

### Attaching Velcro Straps:



Qty.	Item
2	 3/16" x 3/4" fender wood washers

### Attaching Frame & Stiffeners to Bed Panels:





Qty.	Item
135	 #8 x 5/8" panhead screws

### Attaching Legs to

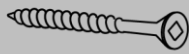

### Crossbar:

Qty.	Item
2	 1/4" x 20 x 3/4" hex bolts
2	 1/4" internal star washers
1	 Loctite Threadlocker Capsule

### Security Cabinet to Wall:

Qty.	Item
1	 <b>DANGER</b> Warning Label
1	 <b>ATTENTION</b> Attention Label
3	 2" x 2" L bracket
6	 #8 x 2" flathead wood screws
6	 #8 x 3/4" flathead wood screws





### Bed Panel Corner Protection:

Qty.	Item
1	 left panel guard
1	 right panel guard



Bag no. 7 and Bag no. 9 at the back of this page/page 4.

## Bag #7 – Mechanism

### *For Mounting Mechanism to Side Panel:*

	Qty.	Item
	10	5/16" x 1 1/4" flathead machine screws
	10	5/16" plain hexagon nuts
	2	5/16" x 7/8" (OD) flat washers
	2	3/4" hexagon cam washers

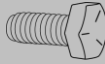
### *Mounting mechanism to Bed Frame:*

	Qty.	Item
	4	5/16" x 18 x 3/4" hex bolt
	2	5/16" x 3/4" carriage bolts
	6	5/16" nylock hexagon nuts

### *Attaching Mechanism Covers:*

	Qty.	Item
	4	4mm x 1/4" flathead slot machine screws

## Bag #9 – Cabinet Hardware



### *Top Stretcher:*

	Qty.	Item
	3	1/4" rounded bumper buttons

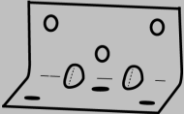

### *Leg Bumpers:*

	Qty.	Item
	2	3/8" flat bumper buttons

### *Attaching Kick, Headboard, Bottom Stretcher:*

	Qty.	Item
	10	1" x 1" x 1 3/4" 6-hole assembly brackets
	60	#8 x 5/8" panhead wood screws

### *Attaching Side Panels to Top Stretcher:*

	Qty.	Item
	6	Confirmat screws
	6	Confirmat screws caps

# CUT LIST - Steel Bed Frame REGULAR LEGS

## Single Twin Bed (Mattress size 39" x 75" x 10" thickness)

Overall Cabinet Dimension: 44½"W x 80 1/16"H x 15 7/8" D Protrusion from wall to foot bed: 84½"				
# of pieces	Description	Width	Length	Material
1	BED PANEL	42 5/8"	77 5/16"	¾" Plycore
2	SIDE PANELS	15 7/8"	80 1/16"	"
1	HEADBOARD	14 7/8"	43"	"
1	TOP STRETCHER	14 7/8"	43"	"
1	BOTTOM STRETCHER	6"	43"	"
1	KICK	1 7/8"	43"	"

## Double/Full Bed (Mattress size 54" x 75" x 10" thickness)

Overall Cabinet Dimension: 59½"W x 80 1/16"H x 15 7/8" D Protrusion from wall to foot bed: 84½"				
# of pieces	Description	Width	Length	Material
2	BED PANEL	28 ¾"	77 5/16"	¾" Plycore
2	SIDE PANELS	15 7/8"	80 1/16"	"
1	HEADBOARD	14 7/8"	58"	"
1	TOP STRETCHER	14 7/8"	58"	"
1	BOTTOM STRETCHER	6"	58"	"
1	KICK	1 7/8"	58"	"

## Queen Bed (Mattress size 60" x 80" x 10" thickness)

Overall Cabinet Dimension: 65½"W x 85 1/16"H x 15 7/8" D Protrusion from wall to foot bed: 89½"				
# of pieces	Description	Width	Length	Material
2	BED PANEL	31 ¾"	82 5/16"	¾" Plycore
2	SIDE PANELS	15 7/8"	85 1/16"	"
1	HEADBOARD	14 7/8"	64"	"
1	TOP STRETCHER	14 7/8"	64"	"
1	BOTTOM STRETCHER	6"	64"	"
1	KICK	1 7/8"	64"	"

**Cut Sheets for extended legs (page 20) and long legs (page 21)**

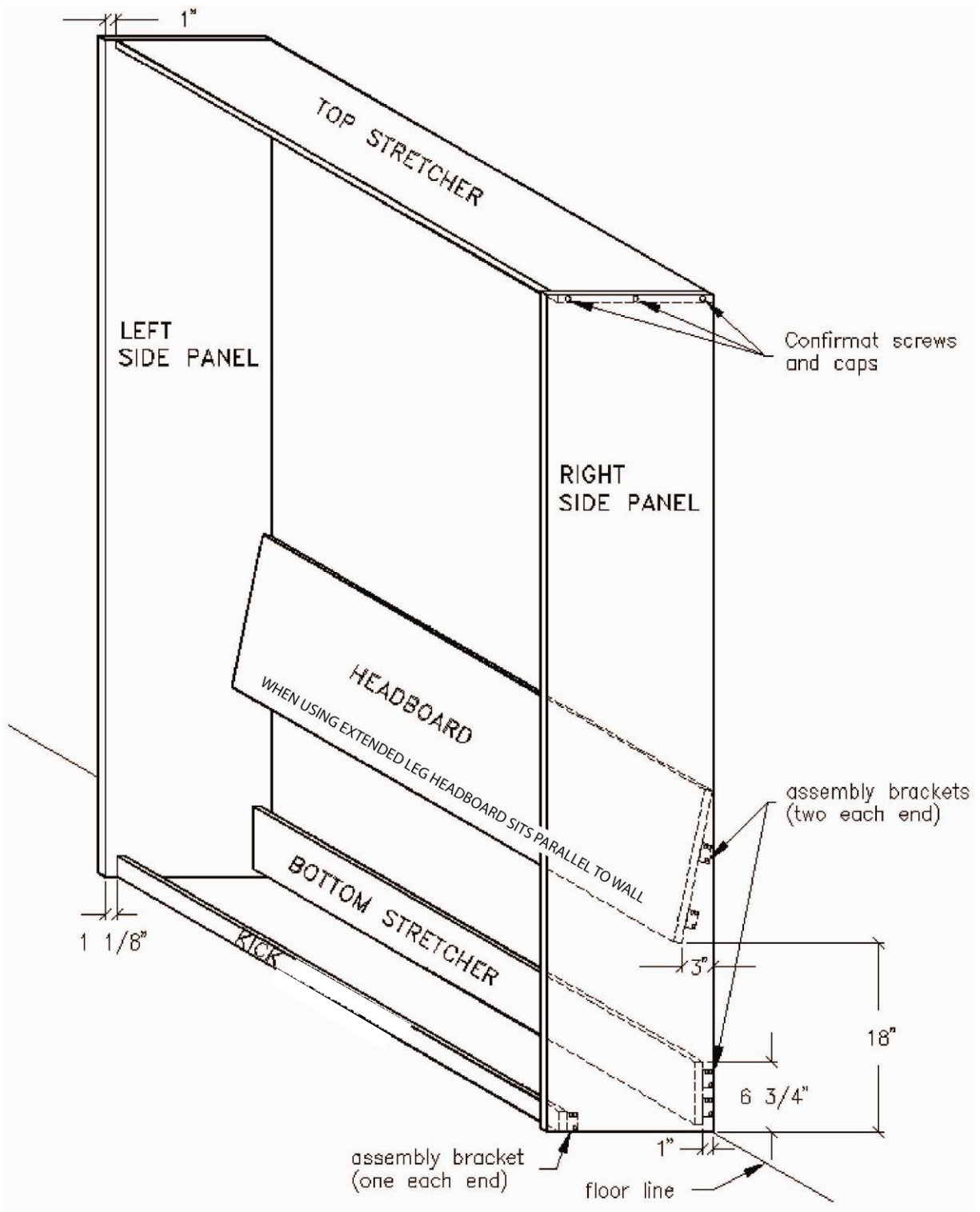

Figure 1. Parts of the Bed Cabinet.

# Bed Cabinet Assembly Instructions

## Helpful Hint

Before you begin, you may wish to visit our website at [www.murphybeds.com](http://www.murphybeds.com) to view the **Quick Time Video** showing the assembly of an Elite Aluminum Frame. Please note that your Supreme Steel Frame does not require the adhesive tape on the frame and stiffeners, and the Supreme Steel stiffeners are attached side to side.

## Please Note:

- Be sure to use the section of the Bed Frame Cut List that corresponds to the size of the bed that you are constructing.
- Do not glue the Bed Cabinet together.

1. Cut panels exactly as specified in the Cut List located on page 5 (reg leg), page 20 (extended leg) and page 21 (Long Leg) of these instructions. As you cut each piece, identify it using a pencil, as indicated in **Figure 1**. Label the Bed Panels (not shown in **Figure 1**) BED PANEL. You will use these names throughout the instructions to reference the particular items.
2. Clean and/or sand pieces. Tape the following edges that will be exposed after construction:
  - TOP STRETCHER & SIDE PANELS – front edges
  - HEADBOARD – both long edges
  - BOTTOM STRETCHER – top edge
  - KICK – both long edges (to prevent bowing)
  - FACE PANELS – all four sides

**Helpful Hint:** The simplest method is to use pre-glued, iron-on tape appropriate for the construction material you are using.
3. Make a small mark on the *inside* of each Side Panel, 3" from the back and 18" from the bottom. From this mark measure up and back  $14\frac{7}{8}$ " to the back edge of the Side Panels. Make another mark and pencil a line to indicate the back of the Headboard Position.
4. Attach 1" x 1" x  $1\frac{3}{4}$ " assembly brackets to the Headboard, Bottom Stretcher and Kick as per **Figure 1**. Note that you must set the top brackets of the Headboard low enough so they do not protrude beyond the back of the cabinet. If you will be notching out Side Panels to accommodate a baseboard, attach the Bottom Stretcher. Brackets to the front side of the notches.
5. Accurately mark the Lift Mechanism mounting holes on the inside of each Side Panel. See **Figure 2** for the layout of these holes. When drilling the holes, first drill a  $\frac{1}{16}$ " hole with a  $\frac{5}{16}$ " bit. Countersink ( $\frac{5}{8}$ " diameter) each hole on the outside of the panels, just deep enough for the head of the  $\frac{5}{16}$ " x  $1\frac{1}{4}$ " flathead slot machine screw to sit flush with the surface. (You can sand and paint the machine screws' heads to match your Cabinet finish.)
6. Align the back edges of the Top Stretcher and the Side Panels and clamp with 72" bar clamps. Using a  $\frac{3}{16}$ " (5mm) bit, drill three Confirmat screw holes per side to a depth of 2". Keep the outer holes 1" away from the front and back edges of the Top Stretcher. Center the third hole between them. Unclamp and re-drill the Side Panel (shank) holes using a  $\frac{9}{32}$ " (7mm) drill bit. Do not countersink these holes. See **Figure 3**.
7. Prior to assembling the Bed Cabinet, you may wish to apply your choice of finish to the individual pieces.
8. You can now begin assembling the Bed Cabinet – if possible, do this in the room where you will install the Bed Cabinet. Refer to Figure 1 for positioning and dimensions. Prop up one Side Panel and the Top Stretcher on their back edges and attach with Confirmat screws. Attach other Side Panel. Press-fit the Confirmat caps.

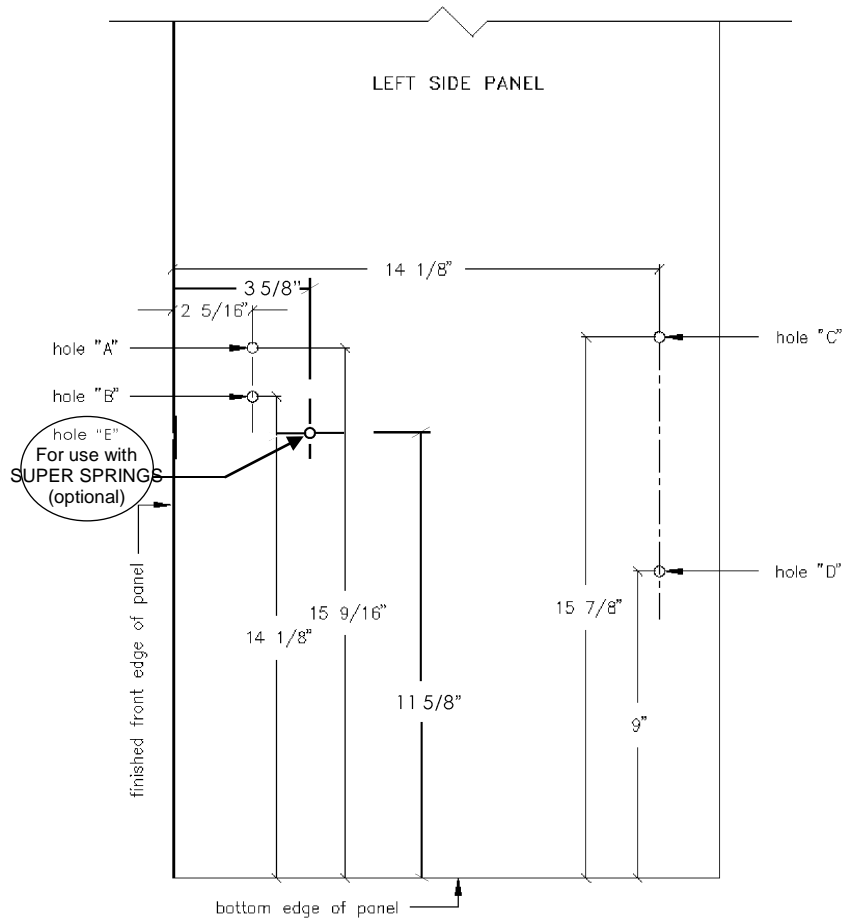

**Figure 2.**  
Laying

out

**IMPORTANT NOTICE:**

See [Page #21](#) for mechanism drill instructions when using the **EXTENDED LEG** option.

See [Page #22](#) for mechanism drill instructions when using the **LONG LEG** option.

the Lift Mechanism mounting holes. Take horizontal measurements from finished front edge.

- Attach Bottom Stretcher, Kick and Headboard using #8 x 5/8" panhead screws. If installing the Cabinet in a carpeted room, raise the Kick so that it sits lightly on top of the carpet. **However, under no circumstances raise the Kick more than 1/4", or it will interfere with bed operation.**

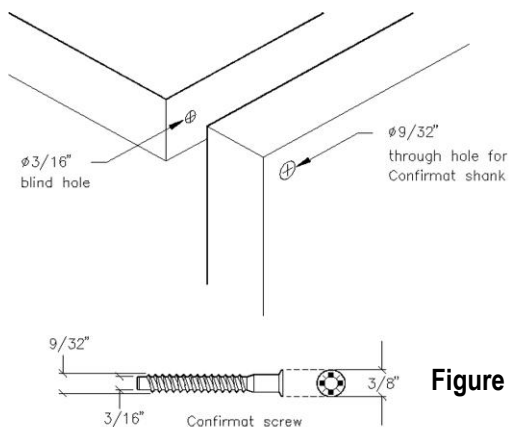

**Figure 3.** Drilling for Confirmat screws.

## Securing the Bed Cabinet

### Attention!

You must secure the Cabinet to solid structural members and not merely to the wall finish. If you are not attaching your bed to a wood stud wall, see your local hardware retailer for metal stud screws or concrete  $1\frac{3}{4}$ " x  $\frac{1}{4}$ " expansion bolts and a concrete drill bit. In either case, be careful not to hit electrical wiring or plumbing behind the drywall.

1. Remove the strip of baseboard where you wish to locate the Cabinet (or notch out the Side Panels) so that the back of the Cabinet is flush against the wall. (Later you can trim and replace the baseboard). Place Cabinet against the wall. If the floor is off-level or not square with the wall, shim or pack the Cabinet with thin strips of wood. Do a preliminary for squareness by measuring diagonally from corner to corner across the face of the cabinet. *It is more important that the cabinet be square than exactly level or plumb.*
2. Use a step ladder to access the wall above the Top Stretcher and locate three studs or some other solid structural members to which you can fasten three 2" x 2" L brackets (see **Figure 4**). *Do not place weight on the Top Stretcher when attaching the brackets, or it will "bow."*

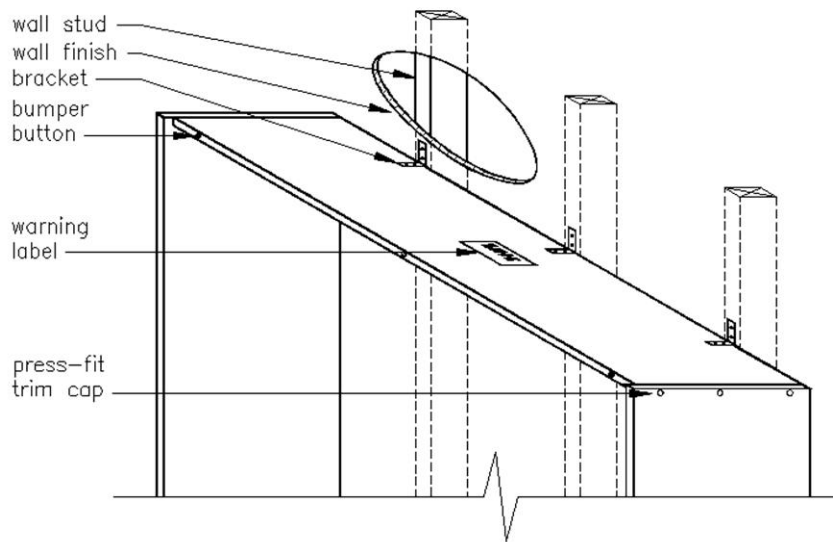

**Figure 4.** Securing the Cabinet.

3. Drive two #8 x 2" flathead wood screws through each bracket and into each solid framing member. Drive a single #8 x  $\frac{3}{4}$ " flathead screw through the middle bracket and into the Top Stretcher, then recheck the Cabinet for square as in Step 1 above. Adjust as necessary and drive five more #8 x  $\frac{3}{4}$ " flathead screws through the brackets and into the Top Stretcher.
4. Peel off the backing and attach Warning Label and three  $\frac{1}{4}$ " round Bumper Buttons (see **Figure 4**).

# Installing Springs in Lift Mechanisms

**Please Note:**

After you have completed installing and checking the operation of your Murphy® Wall-Bed, you may find it necessary to add or remove springs to achieve the correct lift effort of between five and 10 lbs. Please refer to additional notes for tips on how to correctly balance your mattress.

**If using SUPER SPRINGS please refer to the "IMPORTANT NOTICE FOR SUPER SPRINGS" at page 11.**

1. The number of springs in the Lift Mechanism required varies with the different weights of mattresses and construction materials. Select the appropriate number from the chart below.

Bed Size	Bed Panel Material	
	Wood Veneer/Plywood Core	Melamine/Particle Board
Single/Twin	4–5 springs per side	5–6 springs per side
Double/Full	6–7 springs per side	7–8 springs per side
Queen	8–9 springs per side	8–9 springs per side

**Table 3a.** Use bed size to determine required number of springs

2. Since **Figures 5 and 6** show the Right Lift Mechanism, start with that one. Numbering down from the top, the center line runs through spring hole #5. If you are installing an even number of springs, start at hole #4 or #6, leaving hole #5 vacant. Notice that the hook ends of the spring have slightly different sized openings. Hook the end of the spring that has the smallest opening under the upturned edge of the Mounting Plate. Lay the spring down and slide it under the matching hole in the Tension Arm. Be sure to install the springs so that the hook openings face you. See **Figure 5** for further detail.

**Helpful Hints**

- You may find it easier to fit the hooks under the Tension Arm if you pry up the Arm Bracket with a wooden wedge or similar device.
- While an equal number of springs on each side of the centreline is preferred, an imbalance by one spring is acceptable, preferably with the extra spring on the top side. If required, install spring #9 last (see **Figure 5**).

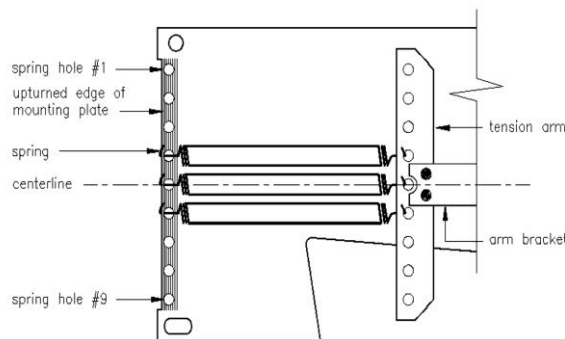

**Figure 5.** Installing the Springs, Right Lift Mechanism.

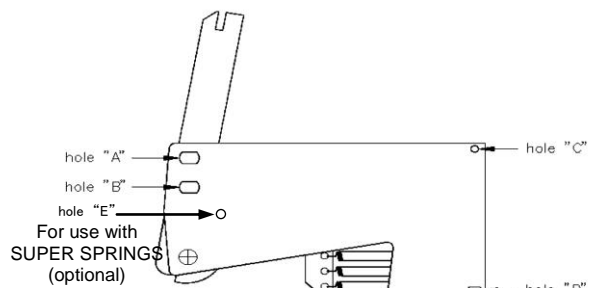

**Figure 6.** Right Lift Mechanism, Back View

3. Continue by working out from the center, alternating top and bottom, until you have installed the required number of springs. Be sure that holes of the Mounting Plate correspond to the holes in the Tension Arm.

**NOTE:** After you have completed installing and checking the operation of your Murphy Bed, you may find it necessary to add or remove springs to achieve the correct lift effort of 5–10 lbs. After placing the mattress in the frame, check to see if the bed is balanced properly.

If you have installed the number of springs as suggested in Table 3a and you find the Murphy Bed “snaps” closed, you may have to remove a spring from each side. The best way to do this is to remove the Bed Panels from the mechanism (follow the reverse order of Point 6 – Install Bed Panel Unit) and **carefully** release the tension on the mechanism arm (follow reverse order of Point 6 – Install Bed Panel Unit) until the spring tension is released. You can use a bolt cutter to cut the spring hook in order to remove a spring. Another alternative is to detach each side by physically removing the springs “by hand.” In order to keep the mechanism “balanced” try to keep the same amount of springs on each side of the centreline (see **Figure 5**). Re-install the Bed Panel Unit.

If you have installed the number of springs as suggested in **Table 3a** and you find the Murphy Bed slowly closes back into place (only a few pounds are needed to keep your Murphy Bed down), we suggest you consider the following options:

- a) Remove only one additional spring from one of the mechanisms (see above instructions).
- b) Screw in one to two  $\frac{3}{4}$ ” Medium Density Fiberboard (MDF) strips under the mattress at the foot of the bed. *MDF is very dense and can be easily screwed into the bottom side of the Bed Panels. Be sure to use screws that are not too long.*

4. Repeat Steps 2 and 3 to install the springs in the Left Lift Mechanism. *Use the same number of springs and the same configuration on both Lift Mechanisms.*

## IMPORTANT NOTICE

### “SUPER SPRING”

- All drilling instructions provided in the Instruction Booklet (to attach the Mechanism to the Side Panels) are based on using the enclosed “Regular Springs”.
- Occasionally you may require stronger springs to support a heavier mattress, face moldings, additional stiffeners, etc., and “Super Springs” are an excellent alternative to provide this support.
- In all cases you should use the maximum number of “Regular Springs” and substitute “Super Springs” (up to a maximum of 2 per side) to assist with the extra weight. Please remember to install the “Super Springs” in the middle of the spring locations.
- If using “Super Springs” we recommend adding an extra bolt when attaching the Mechanism to the Side Panel. The extra bolt (provided with the “Super Springs”) will provide additional support for the Mechanism. Please see the attached drawings for the “fifth hole” drilling pattern.

Please see **figure 2** on page 8

## Mounting Lift Mechanisms

1. Insert a  $\frac{5}{16}$ " x  $1\frac{1}{4}$ " flathead slot machine screw through countersunk hole "C" from the outside of the Right Side Panel. Position the corresponding Right Lift Mechanism hole (see **Figure 6** for location) over the screw. Loosely thread on a  $\frac{5}{16}$ " plain hex nut. Insert a similar screw through each of holes "A", "B", "D" and "E"(optional). At hole "B" use a  $\frac{5}{16}$ " x  $\frac{7}{8}$ " flat washer and a  $\frac{5}{16}$ " plain hex nut. At hole "D" and "E" (optional) thread only a nut on the screw.

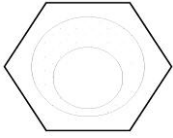

Hex Cam Washer

2. At hole "A" use one of the hexagon cam washers (illustrated left) and a  $\frac{5}{16}$ " plain hex nut. Place the cam washer in the slot of the Mounting Plate so that the larger part of the cam is upward, as in the illustration. *Note: If you are adding a crown moulding, to ensure the correct top clearance turn the Hexagon Cam Washer 180° so that the larger part is downward.* Tighten the four nuts evenly, making sure the Hexagon Cam Washer does not rotate. Do not over-tighten nuts, as this can damage the Side Panel material. Repeat steps 1 through 4 to attach the Left Lift Mechanism to the Left Side Panel. Use the Hex Cam Washer for finite adjustments when placing the bed panels in the surrounding cabinet.

## Assembling the Bed Panel Unit

### Bed Face Panel & Frame

- 2 Bed Panels
- 4 Steel Frame sections
- 2 Stiffeners
- 2 Panel Guards
- 2 Leg Stops
- 4 4-hole Corner Brackets
- 6 black Hole Plugs

1. Lay the Bed Panels face down on a blanket or carpet to protect their outer face. Place a strip of wood, approximately the width of the panels, underneath the head and foot ends to help keep the panel surfaces even. *Note: Identify the head end (located at the bottom of the cabinet when the unit is closed); position the partially drilled handle holes in the centre. Orient the head end closest to the cabinet to facilitate future lifting of the Bed Frame onto the lift mechanism.*
2. The Unit is designed so that there is a  $\frac{1}{16}$ " space between the Panels. Use the Panel Guards as spacers at both ends and tape the Panels together without obstructing the areas where the Frames attach (refer to **Figure 7**).
3. Completely assemble the four Steel Frame sections – two interchangeable side frames, one head frame and one foot frame – using four corner brackets and  $\frac{3}{16}$ " x  $\frac{1}{2}$ " and  $1\frac{1}{4}$ " black screws (see **Figures 7** and **11**). *Be sure the mitred corners fit snugly together.*
4. Position the Bed Frame on the Bed Panels with the Head Frame section **flush** to the head end of the Bed Panels. Ensure the Side Frames run parallel to the side of the Bed Panels and are equal distance ( $\frac{15}{16}$ " ) from the panel edges. Tack the Bed Frames into place, inserting two screws in each frame.  
**IMPORTANT:** *It is very important to center the Bed Frame on the Bed Panels.*
5. The two Steel Stiffeners are fabricated to overlap each side frame (for extra strength). They should be spaced to divide the Bed Panels in three equal sections. Tack the Stiffeners in place with two screws.
6. Once you have confirmed that the Frame and Stiffeners are square and properly placed on the Bed Panels, insert the balance of the screws. Attach the Velcro straps about 18" from the foot of the bed using the  $\frac{3}{16}$ " x  $\frac{3}{4}$ " washer and #8 x  $\frac{3}{4}$ " panhead screw. Ensure the Velcro loops and hooks face each other.

**IMPORTANT!** If you are power-driving the screws that attach the Frames and the Stiffener, be extremely careful not to strip (over-torque) the screw holes. We recommend that you power-drive screws only part way and then tighten by hand. Stripping the holes will automatically void the **Lifetime Warranty** on the Supreme Steel Bed Frame System. Murphy Wall-Beds will not accept any liability for any accidents resulting from improper assembly or installation.

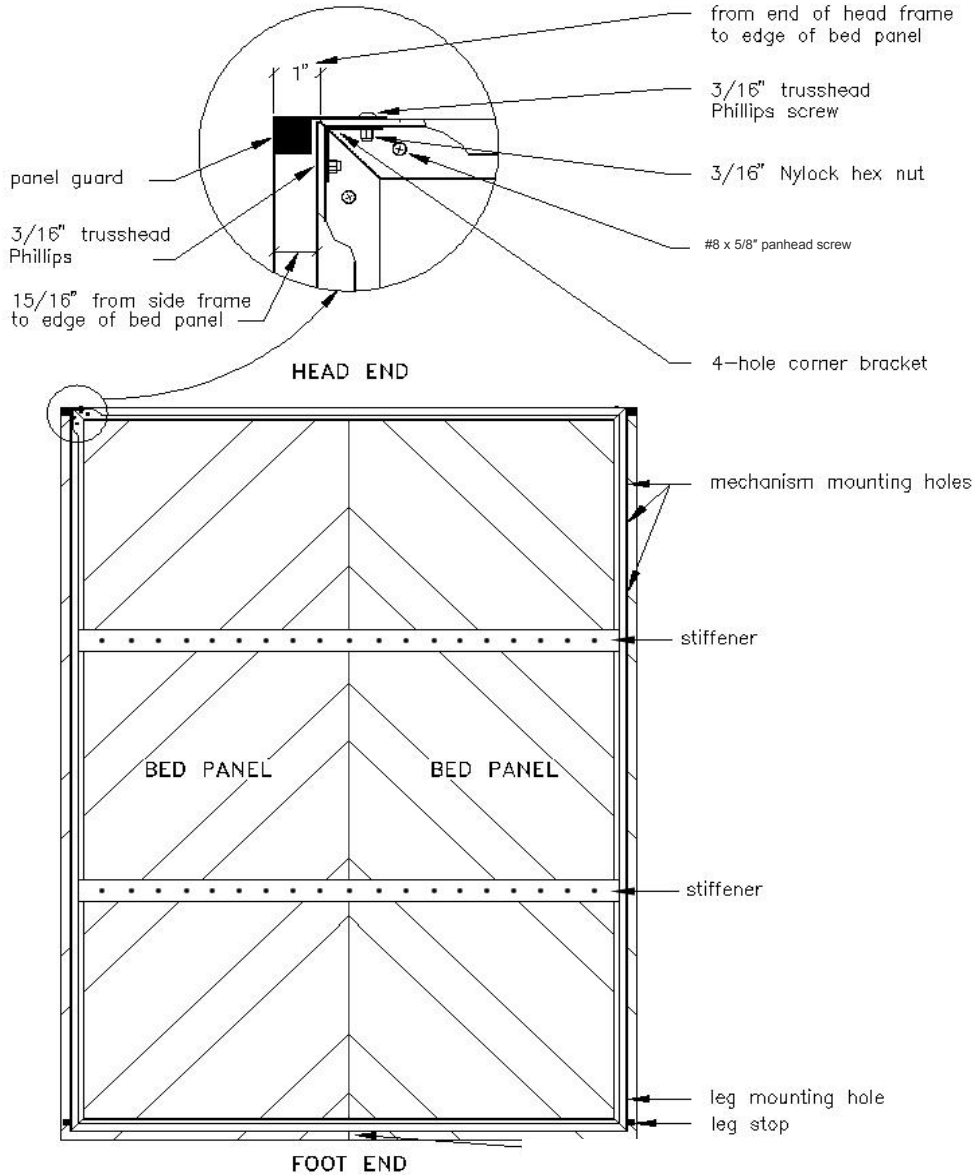

**Figure 7b.** The Bed Panel Unit. Enlarged detail shows Panel Guard and Frame curves cut away to reveal corner bracket.



Install Panel Guards to protect bed without legs in position



Panel Guard Attached to Frame

**Note:** The Panel Guards are intended to provide some protection for the Bed Panels if the bed is lowered without the legs in position, which could cause the bed panels to contact the spring mechanism, possibly damaging the inside of the Bed Panels.

## Installing the Bed Panel Unit

**Note:** The Bed Panel Unit connects to the Cabinet via the Lift Mechanism Tension Arms. You will need someone to help you both set the Arms and lift the Panel Unit into place.

1. Insert the two  $\frac{5}{16}$ " x  $\frac{3}{4}$ " Carriage bolts from the outside of the Side Frames through the #1 holes at the head end of the Bed Panel Unit. Attach one  $\frac{5}{16}$ " Nylock hex nuts on each Carriage bolt end. Thread the nut only until it is flush with the bolt end. Pull the two carriage bolt heads outward so that you have at least a  $\frac{1}{4}$ " space between them and the outside of the Bed Frames (refer to **Figure 8-A** and **Figure 8-B**).
2. Insert two  $\frac{5}{16}$ " x  $\frac{3}{4}$ " hexhead machine bolts from the **outside** of the Side Frames through the #3 holes. Place a  $\frac{5}{16}$ " Nylock nut on each bolt end, threading the nut only until it is flush with the bolt end. Pull the two #3 bolt heads outward so that you have at least a  $\frac{1}{4}$ " space between them and the outside of the Frames (refer to **Figure 8**).
3. Set a  $\frac{5}{16}$ " x  $\frac{3}{4}$ " hexhead bolt and a  $\frac{5}{16}$ " Nylock nut on the floor beside the base of each Side Panel.

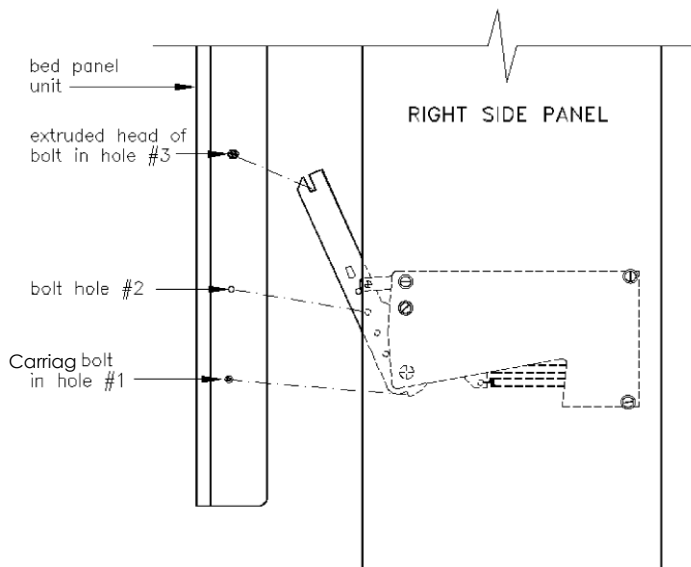

**Figure 8-B.** Carriage Bolt Head

**Figure 8-A.** Installing the Bed Panel Unit.

**IMPORTANT!** Before arming the mechanism make sure KICK is securely attached.

**CAUTION!** The tension on the tension arm is extremely strong. We recommend that two people handle this procedure – one pulling and holding the Tension Arm with both hands while the other sets the Arm Lock. When setting the Arm Lock, **avoid reaching behind the Tension Arm**. Keep fingers safe by using a pencil or screw driver to set the arm lock.

### **Attention!**

As soon as the Bed Panel Unit is connected to the Tension Arm, carefully lower the Bed Panel half way and install the supplied bolt into Hole #2. **Attached the nut and tighten immediately. Next tighten the bolt/nut in Slot #3 and Hole #1. Failure to do secure the supplied bolt and nut as instructed could result in injury.**

4. Sitting on the floor facing the bed cabinet, brace one foot against the front edge of the Side Panel. Using the 13" length of PVC tubing provided, lever the Lift Mechanism Tension Arm straight down in-line with the Side Panel until you can secure the Arm Lock to the hexagon nut that you installed at Hole "A". **Do not pull the Lift Mechanism Tension Arm to the inside of the bed.** This can cause the mechanism arm to bend. **Be sure that the Arm Lock is secured against the hexagon nut before releasing the tension on the pipe lever.** Repeat the operation on the other side.

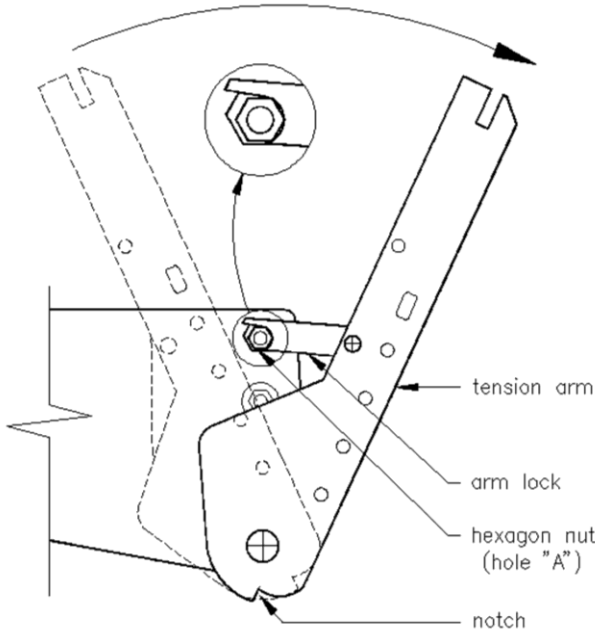

**Figure 9.** Setting the Tension Arm. Enlarged detail shows the arm set securely against the hexagon nut.

5. Locate the 1/2" wrench and adjustable wrench and ensure they are close at hand; then, with you and your assistant on either side of the Bed Panel Unit, lift the foot end so that the unit rests vertically on its head end. Align it between, and just in front of, the Tension Arms. *Caution! Do not bump the Tension Arms in case the Lock Arms slip off the hex nuts.*
6. Lift the unit vertically to a height where the bolts in holes #3 are a couple of inches above the top of the Tension Arms, see **Figure 9**, left. Gently fit the unit between the Arms, tilt it back approximately 10° so that the head end of the unit clears the Kick, then lower it so that the #3 bolts slide into the slots at the ends of the Arms. Be sure the Carriage bolt seats at the bottom of the slots on the tension arm. Slowly tilt the panel unit back just enough to allow the #1 Carriage bolt to be fully seated in the notches at the bottom of the mechanism, see **Figure 10-A** and **Figure 10-B** below.

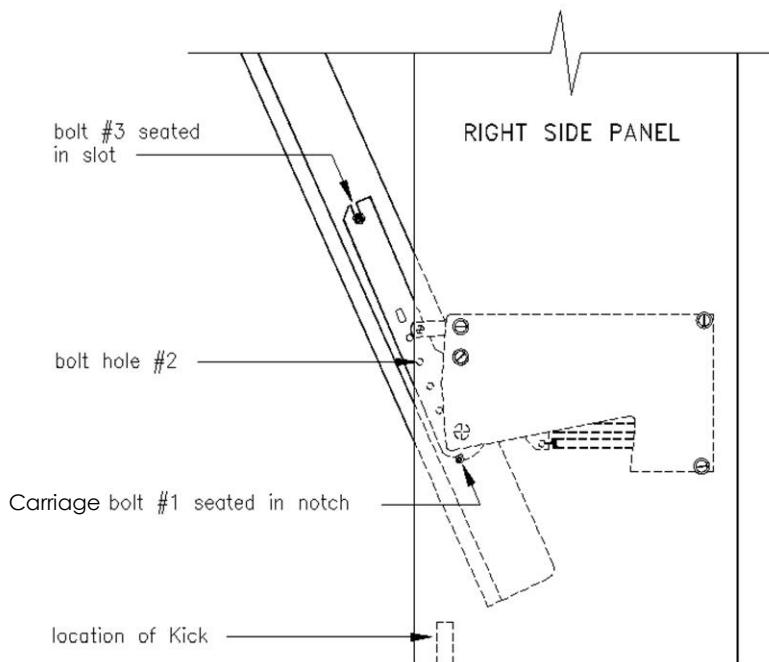

**Figure 10-A.** The Bed Panel Unit in place. It will hold this position *but is not secure until the #2 hole bolt is in place and all nuts are tightened securely.*



**Figure 10-B.** Carriage Bolt tightened against the Bed Frame

7. Continue to tilt the Bed Panel Unit outward to an angle of about 45°, during which action you will hear a click as the Arm Locks disengage. With your assistant holding the bed at roughly this angle, install the #2 bolts and Nylock nuts. Still holding the panel unit at this angle, securely tighten the #1, #2 and #3 nuts.
8. Holding the upper edge of the Bed Panel Unit, gently let the bed close. If all is well, you should have even clearance between the side edges of the panel unit and the insides of the Side Panels.

If the Cabinet is not square and the Bed Panel Unit binds, try the following adjustments:

- nudge the Bed Cabinet along the floor, pushing from the base of the Side Panel;
- shim (or reshim) the bottom of the Side Panels; or
- adjust the Hex Cam Washers.

## Attaching Handles & Legs

**NOTE:** These last few steps will be much easier if your assistant is at hand, simply to hold the Panel that opens.

1. Attach your personal choice of handle(s) to the face of the Bed Panel Unit. To minimize the pull required to open the bed, locate the lowest part of the handle(s) not more than 36" from the top of the unit.
2. Pull the panel unit open to a convenient working height. Remove the  $\frac{5}{16}$ " Nylock hexagon nuts, the  $\frac{5}{16}$ " x  $1\frac{1}{2}$ "(OD) black flat washers and  $\frac{3}{4}$ " x  $1\frac{1}{2}$ " (OD) washers from the legs, leaving the black plastic washers in place. Insert the leg-screws through the frames, replace the  $\frac{3}{4}$ " x  $1\frac{1}{2}$ " washers then the  $\frac{5}{16}$ " x  $1\frac{1}{2}$ " black washers and finally the nuts which are to be tightened.
3. Pivot both legs upward and position the crossbar between the legs. Place a  $\frac{1}{4}$ " x  $\frac{1}{2}$ "(OD) star washer on one of the  $\frac{1}{4}$ " x  $\frac{3}{4}$ " hex-head machine screws. Break open and apply the Loctite Threadlocker capsule onto the threads of the  $\frac{1}{4}$ " x  $\frac{3}{4}$ " hex-head machine screw. Then thread the  $\frac{1}{4}$ " x  $\frac{3}{4}$ " hex-head machine screw through the leg hole and screw into the crossbar as in **Figure 11**. **Do not over-tighten**. Repeat process on other side.

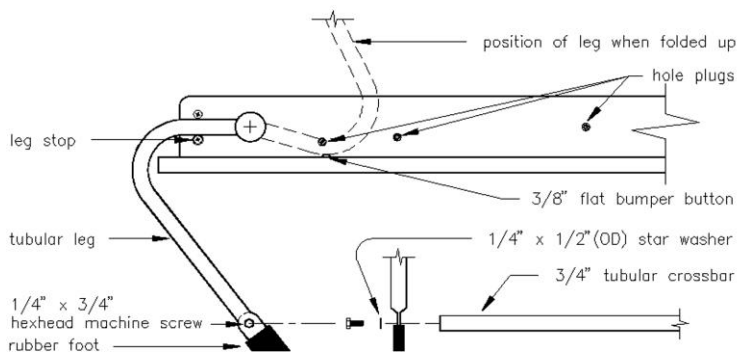

Leg stop in place.

**Figure 11.** Installing the Legs & Crossbar. Viewed is the Right Leg.

4. Attach the two  $\frac{3}{8}$ " flat Bumper Buttons to the surface of the Bed Panels where the legs, when folded up, will contact the Panels (see **Figure 11**). Gently close the bed.

**IMPORTANT:** To avoid damaging the front edge of the Top Stretcher, be sure to fold up the Legs before closing the bed.

## Installing Mattress and Mechanism Covers

1. Have the mattress on hand. Open the bed, fold down the legs and hold the bed fully open by placing one foot on the Crossbar. Put the mattress in place. Be sure it lies completely within the Frame. The added weight of the mattress should now hold the bed down.

**Note:** Using a thin coil mattress less than 9" thick may require a reduction in the number of springs required to balance the bed. There is a slight chance that you may feel the stiffener through the mattress. Should this be the case, simply fill the spaces between the Stiffeners and the Frames with ½" to ¾" Styrofoam or Foamboard, both of which are very light and will not affect the balance of the bed.

**WARNING!**

For safety assurance purposes and to avoid injury, **you must attach the black plastic Mechanism Covers on each Lift Mechanism** in the manner described in Step 2 above. Failure to do so could result in serious injury and will render the warranty for this product null and void. Murphy Wall-Beds Hardware Inc. is not responsible for any injuries resulting from a failure to complete this important step.

2. **Clip the black plastic Mechanism Covers on each Lift Mechanism** so that the tabs hook into the indents on the back plates. Secure with the four 4 mm x ¼" flathead slot machine screws.
3. Trim the Velcro straps so that they overlap a minimum of 12" and lightly singe the loose ends with a match to seal the nylon. The bed will close fully made up with the straps holding the pillows in place. If you installed the correct number of springs in the Lift Mechanisms, the bed should float at an angle of approximately 45°.

**IMPORTANT!** Before using the bed, allow bed to remain down for 24 hours by placing extra weight on the bed to allow the springs to adjust to their established placement and tension.

# EXTENDED LEG (+ 2 3/8") CUT LIST

All cut lists and drilling dimensions provided on [page 5](#) are based on the height of our **Regular Leg**.

If using the **Extended Leg**, you have **2 options**:

## **Option #1**

If you have used the instruction booklet dimensions on [page 5](#) you must install a sturdy platform base that raises all of the cabinetry a further 2 3/8" off of the floor.

## **Option #2**

If you do not include a 2 3/8" base, you must adjust the cutting dimensions and drill patterns to reflect this option's specific changes. The drilling pattern for the lift mechanism hole A, B, C and D, and the drilling pattern for the headboard will be increased 2 3/8" from the bottom edge of the panel. The distance from the front edge will not change. If using Option #2, you must also adjust cutting dimensions as seen below:

### **Single/Twin Bed** (Mattress Size 39"W x 75"L x 12"Thick) – NO FOAM OR BLOW UPS

Overall Cabinet Dimensions: 44 1/2"W x 82 7/16"H x 15 7/8"D Protrusion from wall to foot of bed: 84 1/2"			
# of Pieces	Description	Width	Length
1	Bed Panel	42 5/8"	77 5/16"
2	Side Panels	15 7/8"	82 7/16"
1	Headboard	14 7/8"	43"
1	Top Stretcher	14 7/8"	43"
1	Bottom Stretcher	6"	43"
1	Front Kick	4 1/4"	43"

### **Double/Full Bed** (Mattress Size 54"W x 75"L x 12" Thick) – NO FOAM OR BLOW UPS

Overall Cabinet Dimensions: 59 1/2"W x 82 7/16"H x 15 7/8"D Protrusion from wall to foot of bed: 84 1/2"			
# of Pieces	Description	Width	Length
2	Bed Panel	28 3/4"	77 5/16"
2	Side Panels	15 7/8"	82 7/16"
1	Headboard	14 7/8"	58"
1	Top Stretcher	14 7/8"	58"
1	Bottom Stretcher	6"	58"
1	Front Kick	4 1/4"	58"

### **Queen Bed** (Mattress Size 60"W x 80"L x 12" Thick) – NO FOAM OR BLOW UPS

Overall Cabinet Dimensions: 65 1/2"W x 87 7/16"H x 15 7/8"D Protrusion from wall to foot of bed: 89 1/2"			
# of Pieces	Description	Width	Length
2	Bed Panel	31 3/4"	82 5/16"
2	Side Panels	15 7/8"	87 7/16"
1	Headboard	14 7/8"	64"
1	Top Stretcher	14 7/8"	64"
1	Bottom Stretcher	6"	64"
1	Front Kick	4 1/4"	64"

# LONG LEG (+ 6 1/8") CUT LIST

All cut lists and drilling dimensions provided on [page 5](#) are based on the height of our **Regular Leg**.

If using the **Long Leg**, you have 2 options:

## **Option #1**

If you have used the instruction booklet dimensions on [page 5](#) you must install a sturdy platform base that raises all of the cabinetry a further 6 1/8" off of the floor.

## **Option #2**

If you do not include a 6 1/8" base, you must adjust the cutting dimensions and drill patterns to reflect this option's specific changes. The drilling pattern for the lift mechanism hole A, B, C and D, and the drilling pattern for the headboard will be increased 6 1/8" from the bottom edge of the panel. You must also adjust cutting dimensions as seen below:

### **Single/Twin Bed (Mattress Size 39"W x 75"L x 15"Thick) – NO FOAM OR BLOW UPS**

Overall Cabinet Dimensions: 44 1/2"W x 82 7/16"H x 21"D Protrusion from wall to foot of bed: 89 5/8"			
# of Pieces	Description	Width	Length
1	Bed Panel	42 5/8"	77 5/16"
2	Side Panels	21"	86 3/16"
1	Headboard	14 7/8"	43"
1	Top Stretcher	20"	43"
1	Bottom Stretcher	6"	43"
1	Front Kick	8"	43"

### **Double/Full Bed (Mattress Size 54"W x 75"L x 15" Thick) – NO FOAM OR BLOW UPS**

Overall Cabinet Dimensions: 59 1/2"W x 82 7/16"H x 21"D Protrusion from wall to foot of bed: 89 5/8"			
# of Pieces	Description	Width	Length
2	Bed Panel	28 3/4"	77 5/16"
2	Side Panels	21"	86 3/16"
1	Headboard	14 7/8"	58"
1	Top Stretcher	20"	58"
1	Bottom Stretcher	6"	58"
1	Front Kick	8"	58"

### **Queen Bed (Mattress Size 60"W x 80"L x 15" Thick) – NO FOAM OR BLOW UPS**

Overall Cabinet Dimensions: 65 1/2"W x 91 3/16"H x 21"D Protrusion from wall to foot of bed: 94 5/8"			
# of Pieces	Description	Width	Length
2	Bed Panel	31 3/4"	82 5/16"
2	Side Panels	21"	91 3/16"
1	Headboard	14 7/8"	64"
1	Top Stretcher	20"	64"
1	Bottom Stretcher	6"	64"
1	Front Kick	8"	64"

### **RETURN PURCHASES:**

All sales will be subject to a 25% restocking fee as well as fees incurred for both outbound and return shipping costs. All returns must be authorized and will be examined upon arrival to our warehouse and subsequent charges may be added for damaged goods. Returns will be accepted within **30 DAYS** from receipt of purchase.

### **DAMAGED or MISSING PARTS:**

In the event of a missing or broken piece, simply call the Murphy Wall-Beds Hardware customer service line at **1-800-667-6336** within **14 days** of your purchase. It is our commitment to you to mail replacement parts, free of charge, within 10 business days of this notification. Replacement parts will not be provided free of charge after the 14 day grace period.

For more information please refer to our website [www.murphybeds.com](http://www.murphybeds.com) under Policies.

These instructions are issued for the exclusive use of the original customer who purchased this product under any of the trademarks or Internet domains, held by MURPHY WALL-BEDS HARDWARE INC. Using the component parts for, or representing and selling this product as a MURPHY BED in Canada or TILT-AWAY BED world-wide may be interpreted as both trademark and copyright infringement. No part of this publication may be reproduced, stored in or introduced into a retrieval system, or transmitted, in any form or by any means (electronic, mechanical, photocopying, or otherwise), without the prior written permission of the copyright owner.



**TOLL FREE 1-800-667-6336**

**PHONE: (604) 576-7880 • FAX: (604) 576-7867**

**E-mail: [info@murphybeds.com](mailto:info@murphybeds.com) - Websites: [www.murphybeds.com](http://www.murphybeds.com)**